

Features

- 1816 0.6mm SMD LED
- High Brightness
- AllnGaP / InGaN Technology
- Top View
- High reliability
- Clear Lens

Applications

- Consumer Electronics
- Wearables
- Automobile After Market
- Industrial Equipment

Description

The IN-S1816TATRGHIR is 1816 top view RGIR package with versatile design capabilities. It is a SMD type molding style LED which can be used in various applications.

Recommended Solder Pattern

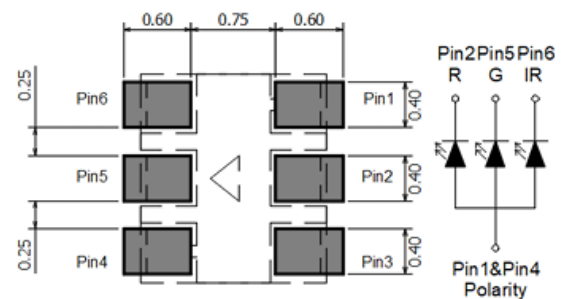
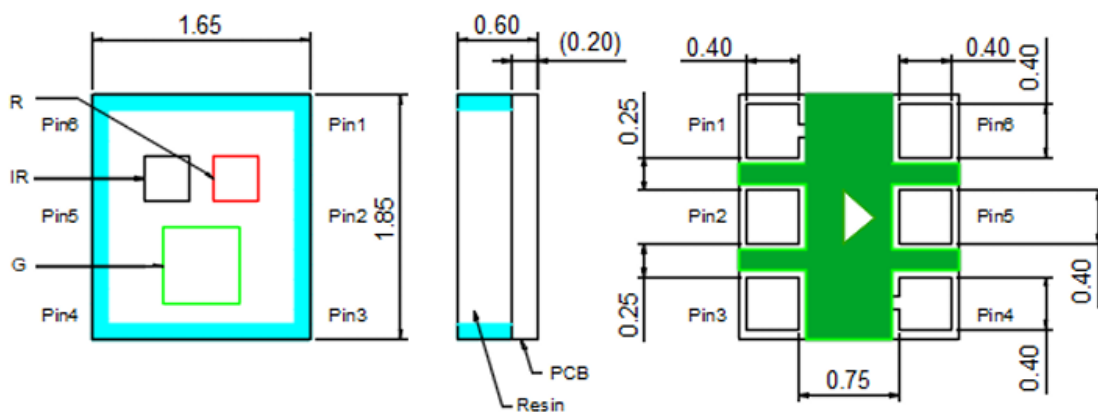

Figure 1. IN-S1816TATRGHIR Solder Pattern

Package Dimensions in mm



Notes.

1. All dimensions are in millimeters.
2. Tolerance is ± 0.10 mm unless otherwise noted

Figure 2. IN-S1816TATRGHIR Package Dimensions

Absolute Maximum Rating at 25°C (Note 1)

Product	Emission Color	I _F (mA)	I _{FP} * (mA)	V _R (V)	T _{OP} (°C)	T _{ST} (°C)
IN-S1816TATRGHIR	Red	20	500	10	-40~+85	-40~+100
	Green	20	400			
	IR	20	500			

Notes

1. Condition for I_{FP} is pulse of 1/10 duty and 0.1msec width

ESD Precaution

ATTENTION: Electrostatic Discharge (ESD) protection



The symbol above denotes that ESD precaution is needed. ESD protection for GaP and AlGaAs based chips is necessary even though they are relatively safe in the presence of low static-electric discharge. Parts built with AlInGaP, GaN, or/and InGaN based chips are **STATIC SENSITIVE** devices. ESD precaution must be taken during design and assembly. If manual work or processing is needed, please ensure the device is adequately protected from ESD during the process.

Please be advised that normal static precautions should be taken in the handling and assembly of this device to prevent damage or degradation which may be induced by electrostatic discharge (ESD).

Electrical Characteristics $T_A = 25^\circ\text{C}$ (Note 1)

Product	Emission Color	I _F (mA)	V _F (V)		λ _c (nm)		Viewing Angle	I _e (mW/sr)	
			min	max	min	max		min	max
IN-S1816TATRGHIR	Red	20	1.75	2.4	652	657	120	2.5	7
	Green	20	2.2	2.8	520	540	120	2.2	5.4
	IR	20	1.1	1.8	920	940	120	1.65	4.05

Notes

1. Performance guaranteed only under conditions listed in above tables.

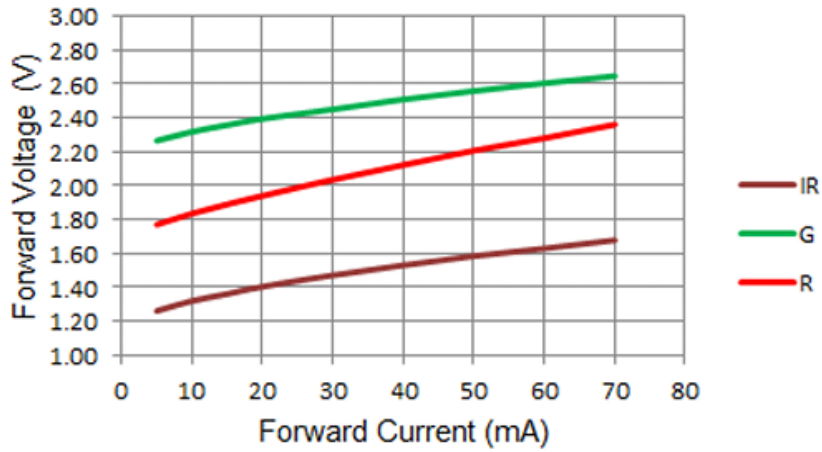
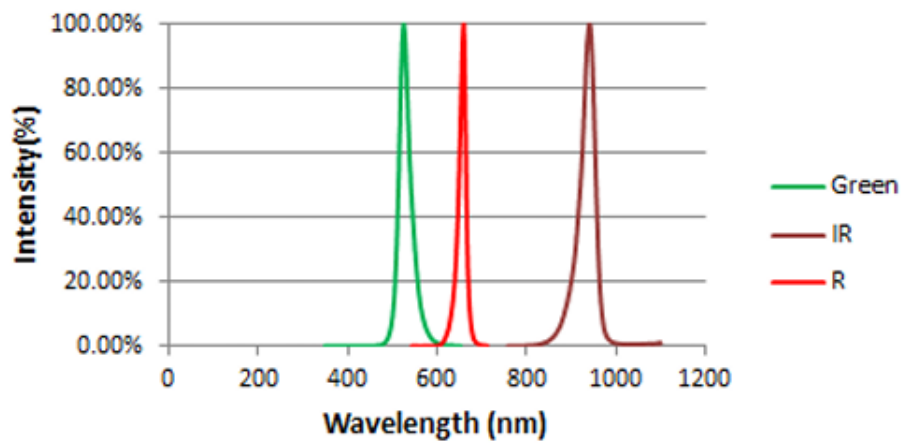
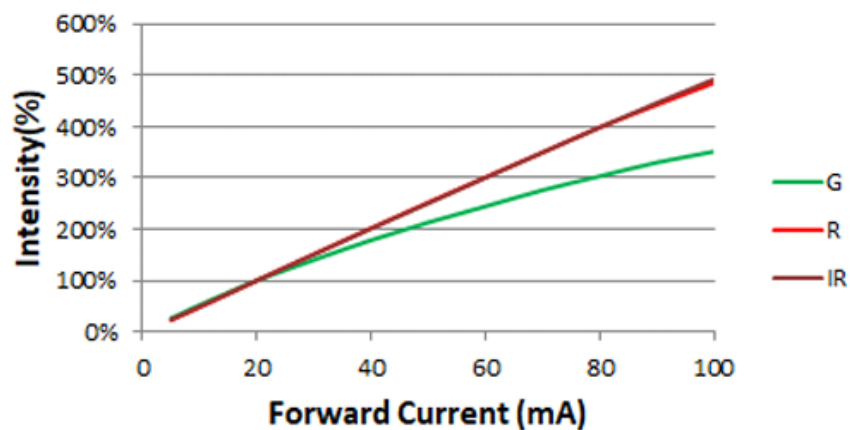
Typical Characteristic Curves – R/G/IR
Forward Voltage VS. Forward Current

Relative Spectral Emission

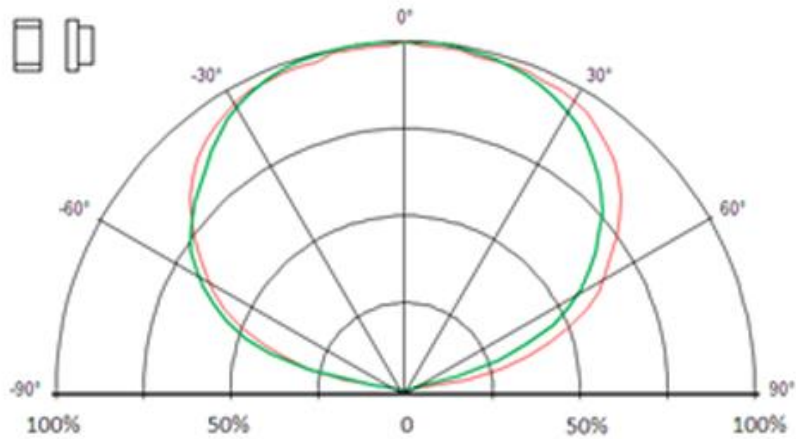
Relative Intensity vs. Forward Current

Typical Characteristic Curves – Radiation Pattern



Ordering Information

Product	Emission Color	Technology	Test Current I_F (mA)	I_e (mW/sr) (Typ.)	Forward Voltage V_F (V) (Typ.)	Orderable Part Number
IN-S1816TATRGHIR	Red	AlInGaP	20	4	2.0	IN-S1816TATRGHIR
	Green	InGaN	20	3	2.4	
	IR	AlInGaP	20	2	1.4	

Label Specifications

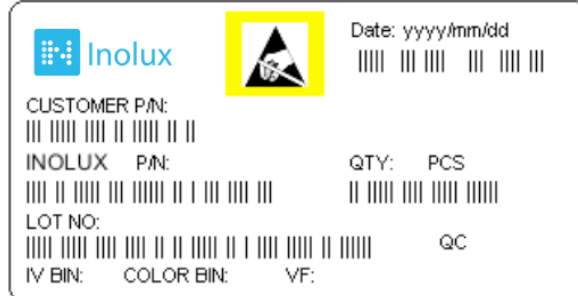

Inolux P/N:

I	N	-	S	1816	T	A	T			R	G	HIR	-	-	-	-	-
Inolux SMD		Material	Package	Variation	Orientation	Current	Lens	Color			Customized Stamp-off						
		S = PCB Type	1816TA = 1.85 x 1.65 x 0.6mm Tri-Chip		T = Top Mount	(Blank) = 20mA	(Blank) = Clear	R=655nm G=530nm HIR=930nm			-						

Lot No.:

Z	2	0	1	7	01	24	001
Internal Tracker	Year (2017, 2018,)				Month	Date	Serial

Packaging Information: 3000pcs Per Reel

Tape Dimension

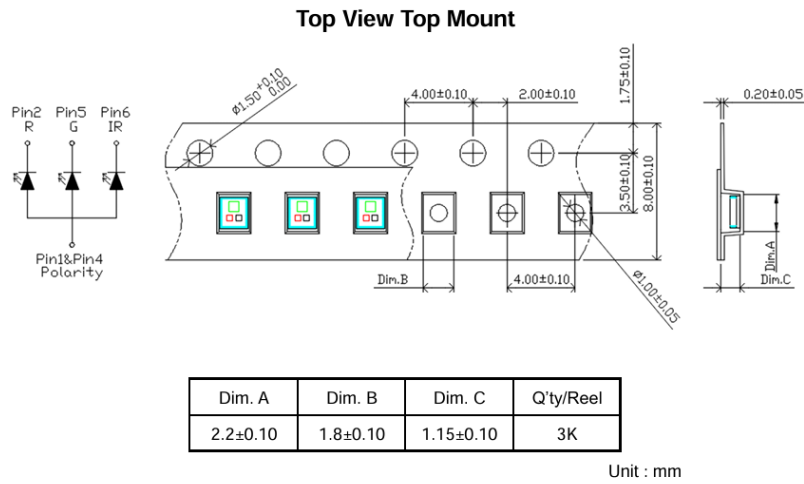

Unit: mm Tolerance: +/-0.10 mm

Reel Dimension

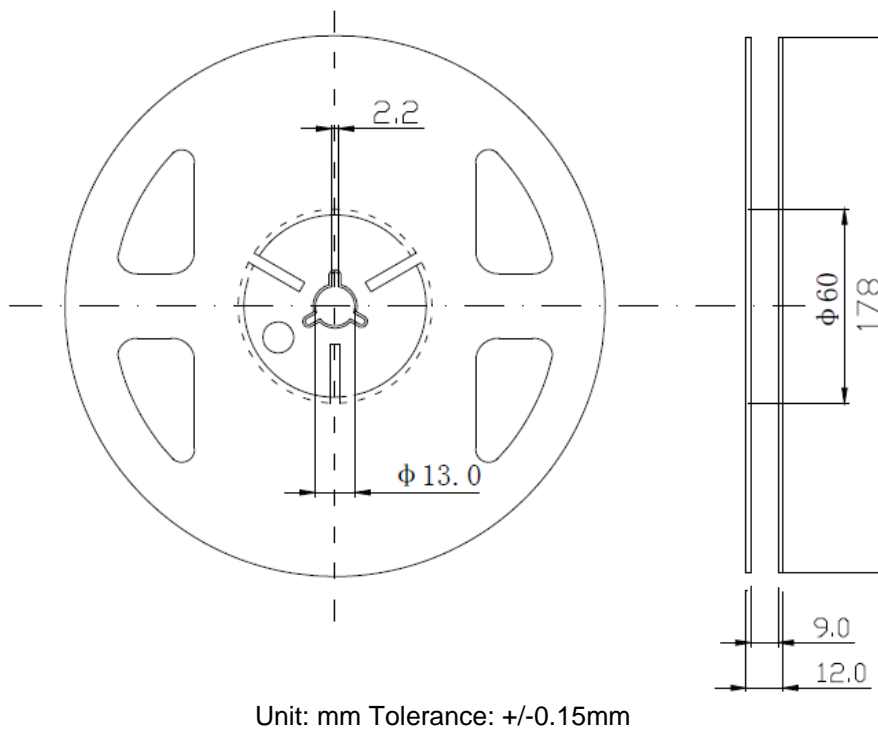

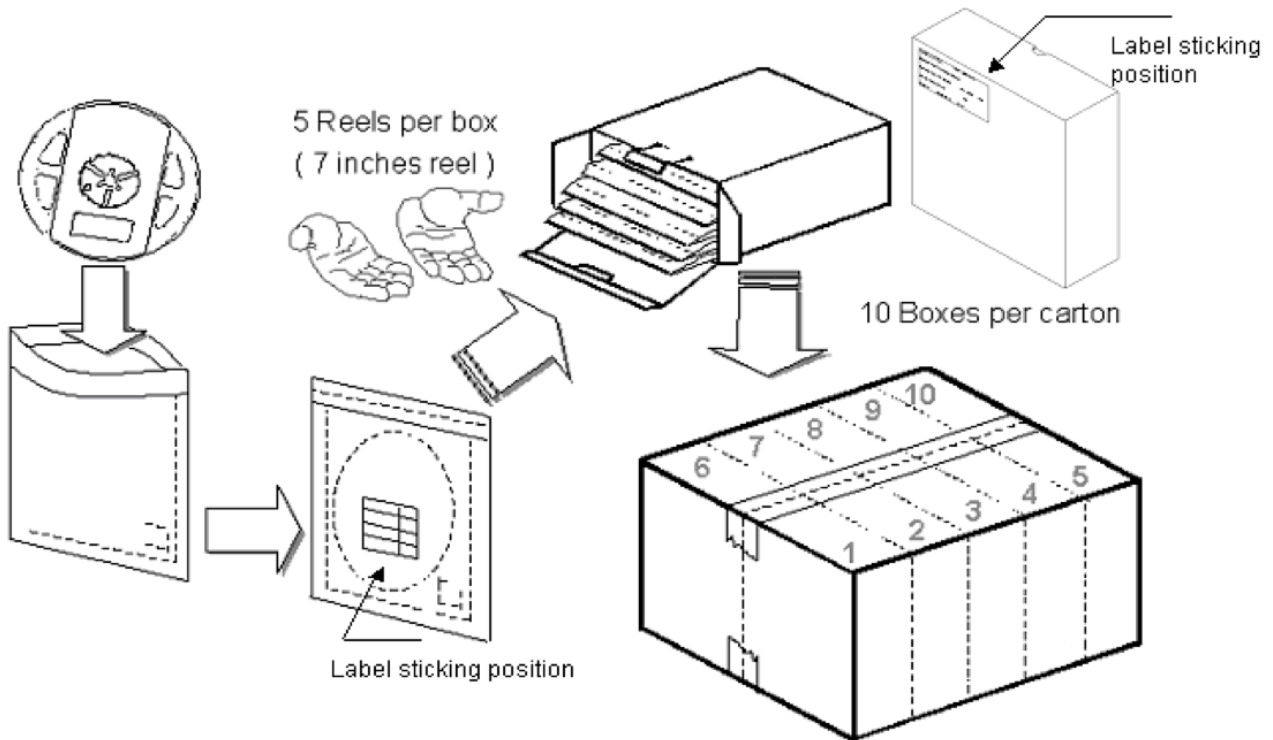
Packing Dimension

5 boxes per carton are available depending on shipment quantity.

	Specification	Material	Quantity
Carrier tape	Per EIA 481-1A specs	Conductive black tape	3000pcs per reel
Reel	Per EIA 481-1A specs	Conductive black	
Label	IN standard	Paper	
Packing bag	220x240mm	Aluminum laminated bag/ no-zipper	One reel per bag
Carton	IN standard	Paper	Non-specified

Others:

Each immediate box consists of 5 reels. The 5 reels may not necessarily have the same lot number or the same bin combinations of I_v , λ_D and V_f . Each reel has a label identifying its specification; the immediate box consists of a product label as well.

Dry Pack

All SMD optical devices are **MOISTURE SENSITIVE**. Avoid exposure to moisture at all times during transportation or storage. Every reel is packaged in a moisture protected anti-static bag. Each bag is properly sealed prior to shipment.

Upon request, a humidity indicator will be included in the moisture protected anti-static bag prior to shipment.

The packaging sequence is as follows:

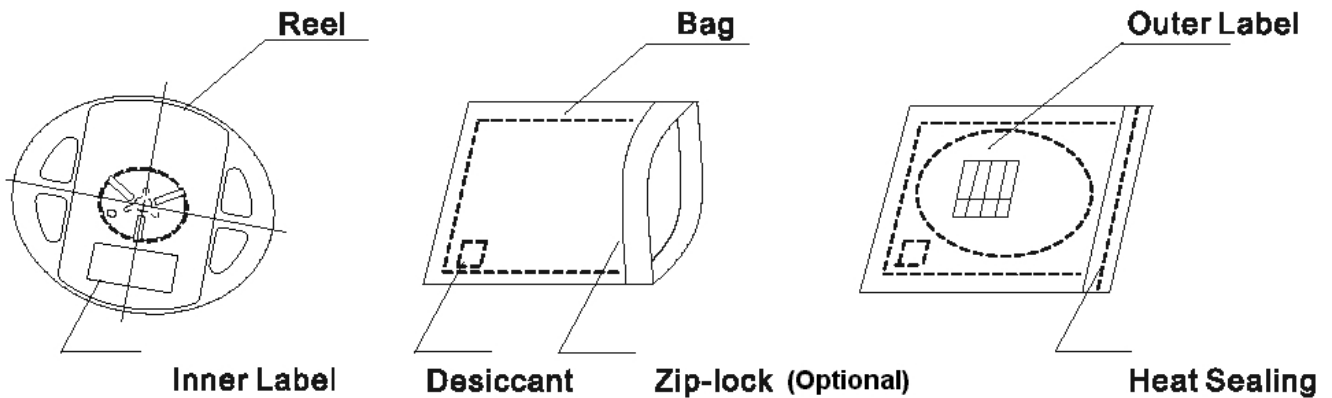

Reflow Soldering

- Recommended tin glue specifications: melting temperature in the range of 178~192 °C
- The recommended reflow soldering profile is as follows (temperatures indicated are as measured on the surface of the LED resin):

Lead-free Solder Profile

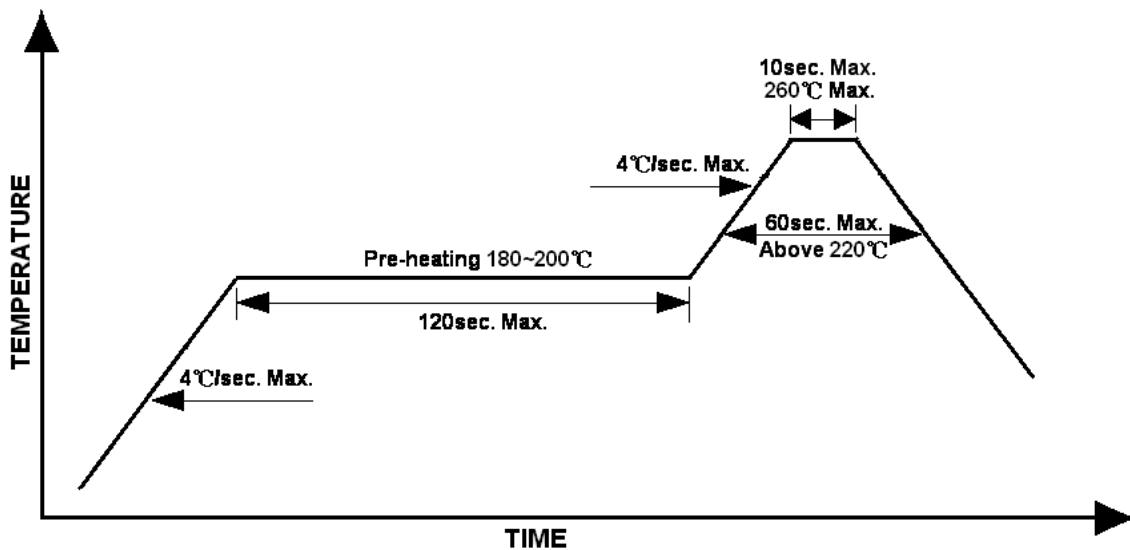

Precautions

- Avoid exposure to moisture at all times during transportation or storage.
- Anti-Static precaution must be taken when handling GaN, InGaN, and AlInGaP products.
- It is suggested to connect the unit with a current limiting resistor of the proper size. Avoid applying a reverse voltage.
- Avoid operation beyond the limits as specified by the absolute maximum ratings.
- Avoid direct contact with the surface through which the LED emits light.
- If possible, assemble the unit in a clean room or dust-free environment.

Reworking

- Rework should be completed within 5 seconds under 260 °C.
- The iron tip must not come in contact with the copper foil.
- Twin-head type is preferred.

Cleaning

Following are cleaning procedures after soldering:

- An alcohol-based solvent such as isopropyl alcohol (IPA) is recommended.
- Temperature x Time should be 50°C x 30sec. or <30°C x 3min
- Ultra sonic cleaning: < 15W/ bath; bath volume ≤ 1liter
- Curing: 100 °C max, <3min

Cautions of Pick and Place

- Avoid stress on the resin at elevated temperature.
- Avoid rubbing or scraping the resin by any object.
- Electro-static may cause damage to the component. Please ensure that the equipment is properly grounded. Use of an ionizer fan is recommended.

Revision History

Changes since last revision	Page	Version No.	Revision Date
Initial Release		1.0	01-14-2025
Updated	2	1.1	03-27-2025
Updated	2	1.2	05-06-2025

DISCLAIMER

INOLUX reserves the right to make changes without further notice to any products herein to improve reliability, function or design. INOLUX does not assume any liability arising out of the application or use of any product or circuit described herein; neither does it convey any license under its patent rights, nor the rights of others.

LIFE SUPPORT POLICY

INOLUX's products are not authorized for use as critical components in life support devices or systems without the express written approval of the President of INOLUX or INOLUX CORPORATION. As used herein:

1. Life support devices or systems are devices or systems which, (a) are intended for surgical implant into the body, or (b) support or sustain life, and (c) whose failure to perform when properly used in accordance with instructions for use provided in the labeling, can be reasonably expected to result in a significant injury of the user.
2. A critical component in any component of a life support device or system whose failure to perform can be reasonably expected to cause the failure of the life support device or system, or to affect its safety or effectiveness.