

Features

- 1808 package (1.8 x 0.8 x 0.55mm) top-mount SMD LED
- High brightness output
- AllInGaP chip technology
- Compact package size
- High reliability performance
- Clear lens configuration

Applications

- Consumer electronics
- Wearable
- Automobile aftermarket
- Industrial equipment

Description

The IN-P18ATR is a popular low profile 1808 package with versatile design capabilities. It is a PLCC type silicone style LED which can be used in various applications.

Recommended Solder Pattern

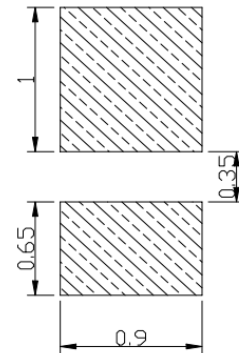

Package Dimensions in mm

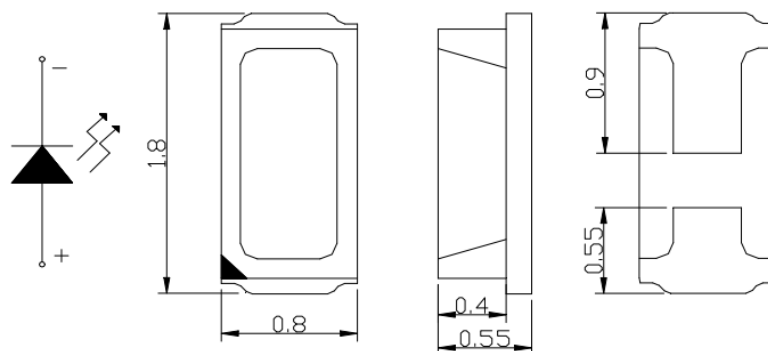

Notes.

1. All dimensions are in millimeters.
2. Tolerance is ± 0.10 mm unless otherwise noted

Absolute Maximum Rating $T_A = 25^\circ\text{C}$ (Note)

Product	Emission Color	P_d (mW)	I_F (mA)	I_{FP}^* (mA)	V_R (V)	T_{OP} ($^\circ\text{C}$)	T_{ST} ($^\circ\text{C}$)
IN-P18ATR	Red	65	25	100	5	$-30^\circ\text{C}\sim+85^\circ\text{C}$	$-40^\circ\text{C}\sim+90^\circ\text{C}$

Note

1. Condition for IFP is pulse of 1/10 duty and 0.1msec width

ESD Precaution

ATTENTION: Electrostatic Discharge (ESD) protection



The symbol above denotes that ESD precaution is needed. ESD protection for GaP and AlGaAs based chips is necessary even though they are relatively safe in the presence of low static-electric discharge. Parts built with AlInGaP, GaN, or/and InGaN based chips are STATIC SENSITIVE devices. ESD precaution must be taken during design and assembly. If manual work or processing is needed, please ensure the device is adequately protected from ESD during the process.

Please be advised that normal static precautions should be taken in the handling and assembly of this device to prevent damage or degradation which may be induced by electrostatic discharge (ESD).

Electrical Characteristics $T_A = 25^\circ\text{C}$ (Note)

Product	Emission Color	$I_F(\text{mA})$	$V_F(\text{V})$		$\lambda(\text{nm})$			Viewing Angle ($^\circ$)	$IV(\text{mcd})$
			min	max	λ_D	λ_P	$\Delta\lambda$	$2\theta_{1/2}$	typ.
IN-P18ATR	Red	20	1.8	2.6	620	630	20	120	230

Note

1. Performance guaranteed only under conditions listed in above tables.

Luminous Intensity (mcd) Bin:

Bin	Luminous Intensity (mcd)	
	Minimum	Maximum
M1	180	230
M2	230	285
N1	285	350
N2	350	450

@20mA / $T_a=25^\circ\text{C}$, Tolerance: $\pm 15\%$

Wavelength (nm) Bin:

Color	Bin Code	Spec. Range
Red	A	615-620 nm
	B	620-625 nm
	C	625-630 nm

@20mA / $T_a=25^\circ\text{C}$, Tolerance: $\pm 1.0\text{nm}$

Forward Voltage (V) Bin:

Color	Bin Code	Spec. Range
Red	1	1.8-2.0 V
	2	2.0-2.2 V
	3	2.2-2.4 V
	4	2.4-2.6 V

@20mA / $T_a=25^\circ\text{C}$, Tolerance: $\pm 0.1\text{V}$

Typical Characteristic Curves

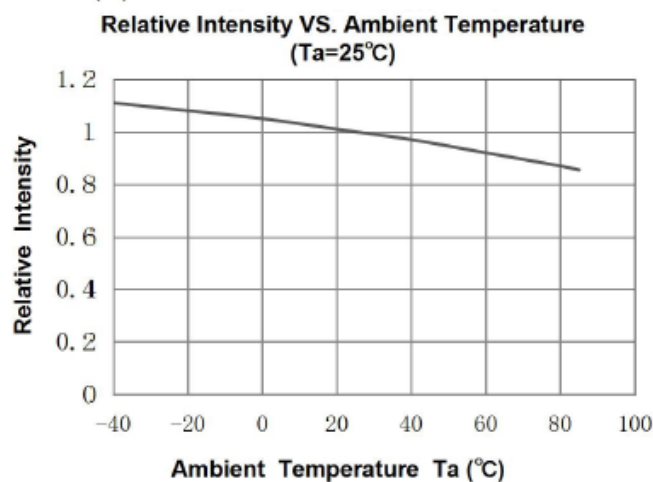
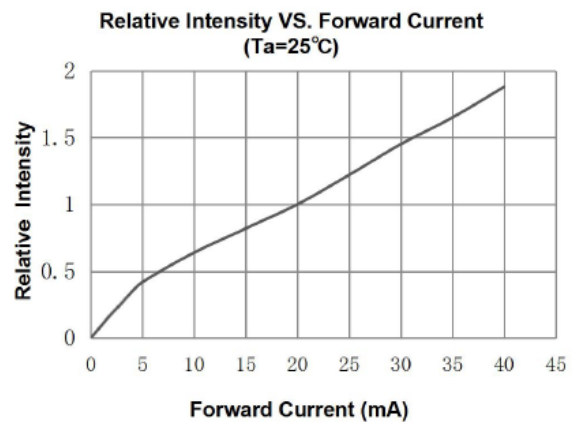
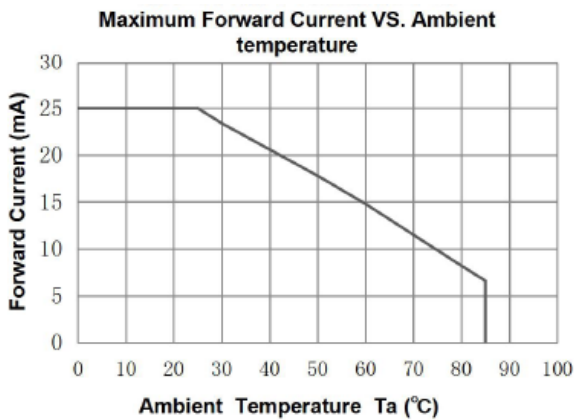
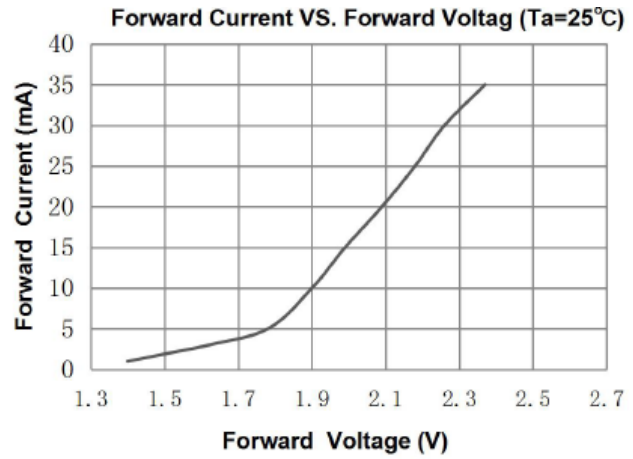
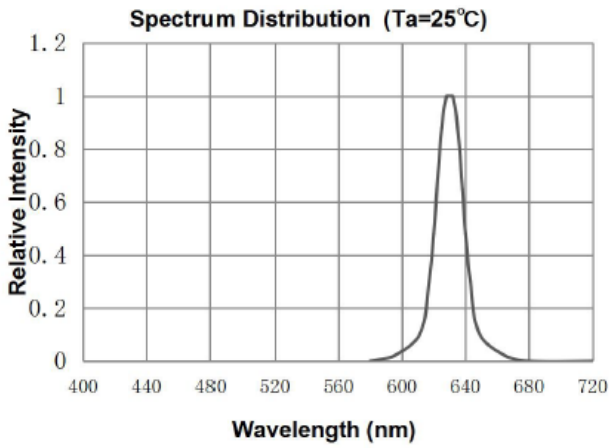

Typical Characteristic Curves – Radiation Pattern

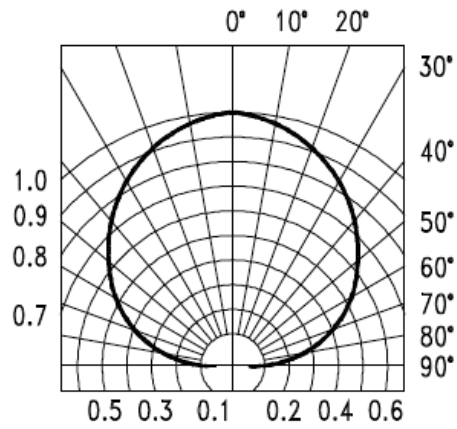

Ordering Information

Orderable Part Number	Emission Color	Technology	Test Current I_F (mA)	Luminous Intensity I_v (mcd) (Typ.)	Forward Voltage V_F (V) (Typ.)
IN-P18ATR	Red	AllnGaP	20	230	2.2

Label Specifications

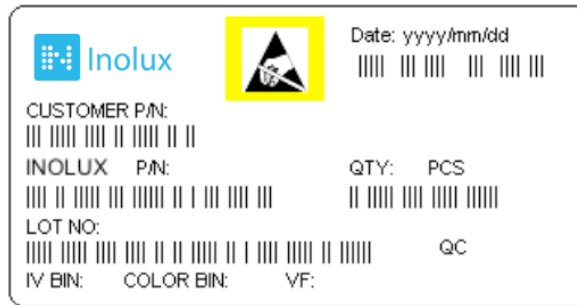

Inolux P/N:

I	N	-	P	1	8	A	T			R	-	-	-	-	-
Inolux			Material	Package		Variation	Orientation	Current	Lens	Color		Customized Stamp-off			
Inolux			P = PLCC Type	18A = 1.8 x 0.8 x 0.55mm			T = Top Mount	(Blank) = 20mA	(Blank) = Clear U = Diffused	R=620nm		-			

Lot No.:

Z	2	0	1	7	01	24	001
Internal Tracker	Year (2017, 2018,)				Month	Date	Serial

Packaging Information: 5000pcs Per Reel

Tape Dimension

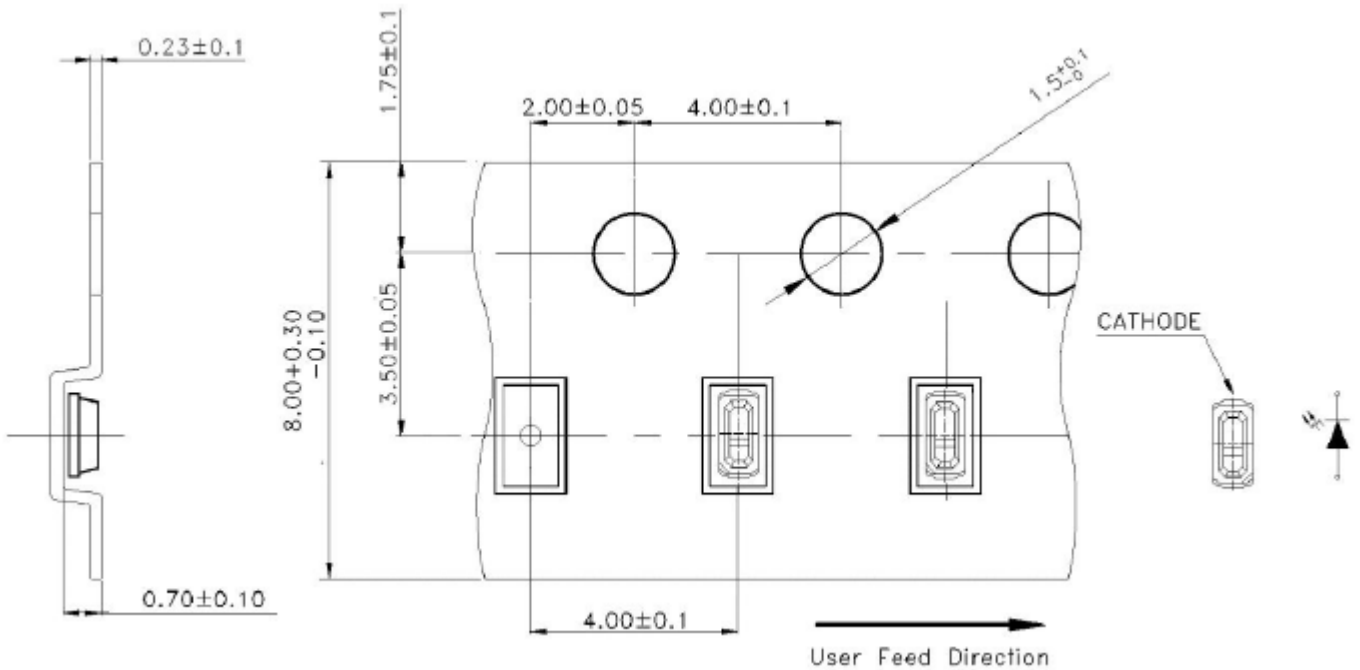

Reel Dimension

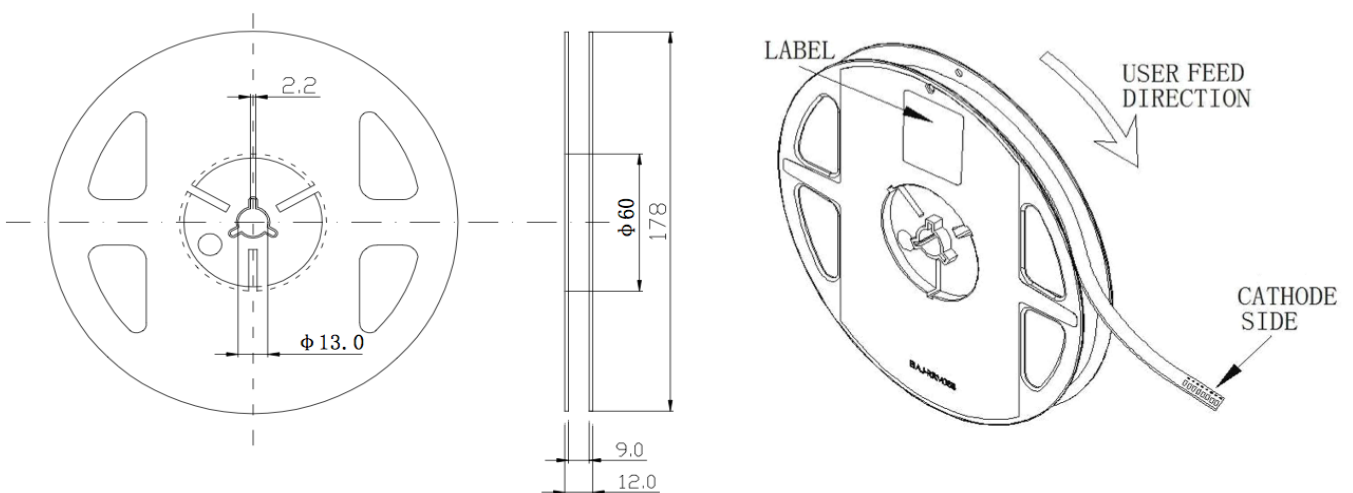

Packing Dimension

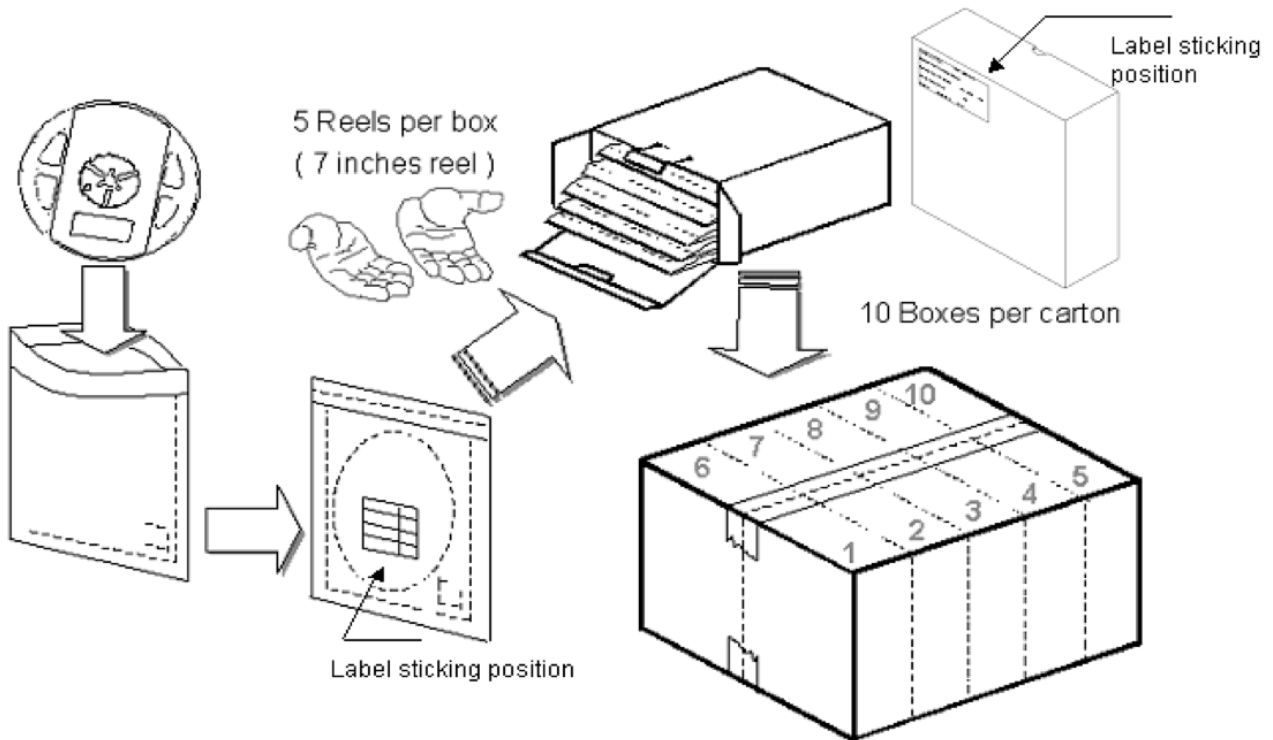

5 boxes per carton are available depending on shipment quantity.

	Specification	Material	Quantity
Carrier tape	Per EIA 481-1A specs	Conductive black tape	5000pcs per reel
Reel	Per EIA 481-1A specs	Conductive black	
Label	Standard	Paper	
Packing bag	220x240mm	Aluminum laminated bag/ no-zipper	One reel per bag
Carton	Standard	Paper	Non-specified

Others:

Each immediate box consists of 5 reels. The 5 reels may not necessarily have the same lot number or the same bin combinations of I_v , λ_p and V_f . Each reel has a label identifying its specification; the immediate box consists of a product label as well.

Dry Pack

All SMD optical devices are **MOISTURE SENSITIVE**. Avoid exposure to moisture at all times during transportation or storage. Every reel is packaged in a moisture protected anti-static bag. Each bag is properly sealed prior to shipment.

Upon request, a humidity indicator will be included in the moisture protected anti-static bag prior to shipment.

The packaging sequence is as follows:

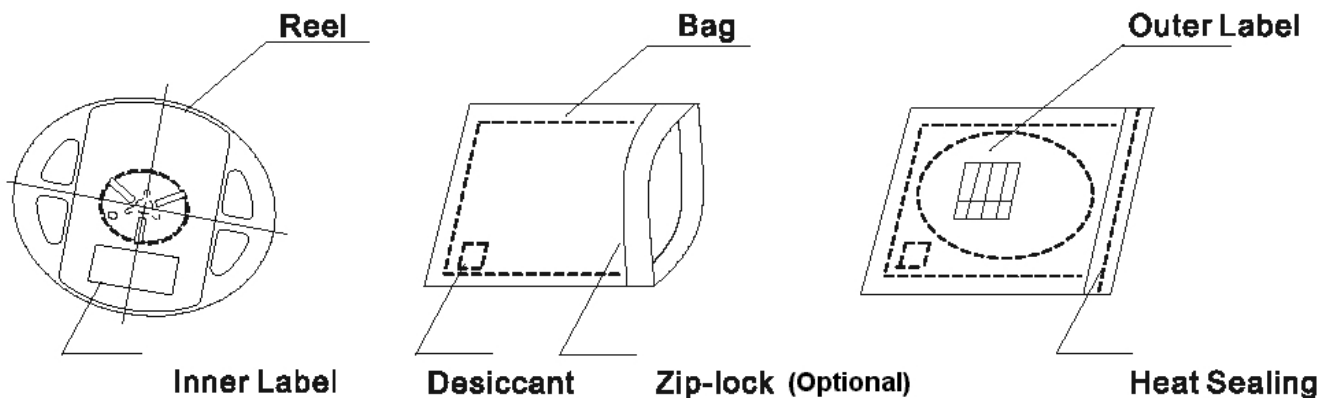

Reflow Soldering

- Recommended tin glue specifications: melting temperature in the range of 178~192 °C
- The recommended reflow soldering profile is as follows (temperatures indicated are as measured on the surface of the LED resin):

Lead-free Solder Profile

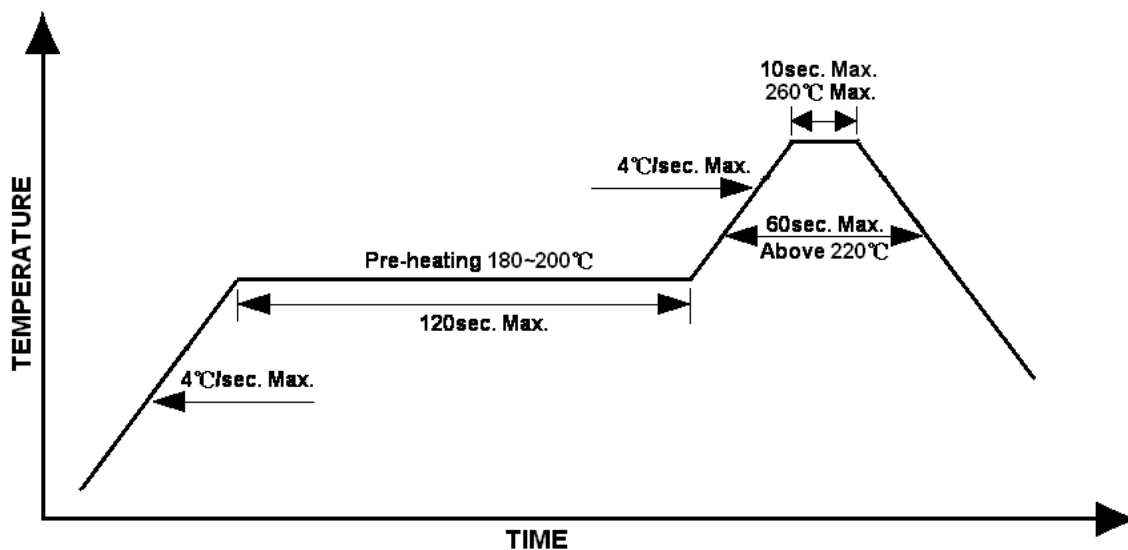

Precautions

- Avoid exposure to moisture at all times during transportation or storage.
- Anti-Static precaution must be taken when handling GaN, InGaN, and AlInGaP products.
- It is suggested to connect the unit with a current limiting resistor of the proper size. Avoid applying a reverse voltage.
- Avoid operation beyond the limits as specified by the absolute maximum ratings.
- Avoid direct contact with the surface through which the LED emits light.
- If possible, assemble the unit in a clean room or dust-free environment.

Reworking

- Rework should be completed within 5 seconds under 260 °C.
- The iron tip must not come in contact with the copper foil.
- Twin-head type is preferred.

Cleaning

Following are cleaning procedures after soldering:

- An alcohol-based solvent such as isopropyl alcohol (IPA) is recommended.
- Temperature x Time should be 50°C x 30sec. or <30°C x 3min
- Ultra sonic cleaning: < 15W/ bath; bath volume ≤ 1liter
- Curing: 100 °C max, <3min

Cautions of Pick and Place

- Avoid stress on the resin at elevated temperature.
- Avoid rubbing or scraping the resin by any object.
- Electro-static may cause damage to the component. Please ensure that the equipment is properly grounded. Use of an ionizer fan is recommended.

Revision History

Changes since last revision	Page	Version No.	Revision Date
Initial Release		1.0	05-12-2021
Updated	1	1.1	08-09-2022
Updated (5000pcs/Reel) - <u>PCN NO: PCN IN 260403-01</u>	7/8	1.2	04-03-2026

DISCLAIMER

INOLUX reserves the right to make changes without further notice to any products herein to improve reliability, function or design. INOLUX does not assume any liability arising out of the application or use of any product or circuit described herein; neither does it convey any license under its patent rights, nor the rights of others.

LIFE SUPPORT POLICY

INOLUX's products are not authorized for use as critical components in life support devices or systems without the express written approval of the President of INOLUX or INOLUX CORPORATION. As used herein:

1. Life support devices or systems are devices or systems which, (a) are intended for surgical implant into the body, or (b) support or sustain life, and (c) whose failure to perform when properly used in accordance with instructions for use provided in the labeling, can be reasonably expected to result in a significant injury of the user.
2. A critical component in any component of a life support device or system whose failure to perform can be reasonably expected to cause the failure of the life support device or system, or to affect its safety or effectiveness.