

Features

- 4545 UVC LED
- ROHS and REACH Compliant
- MSL 3 qualified according to J-STD 020

Description

The IN-C45PPATKU1 is a high-power UVC LED. It is a SMD type LED which can be used in various applications.

Applications

- Medical applications
- Industrial facility applications

Recommended Solder Pattern

(Suggest Stencil $t=0.12$ mm)

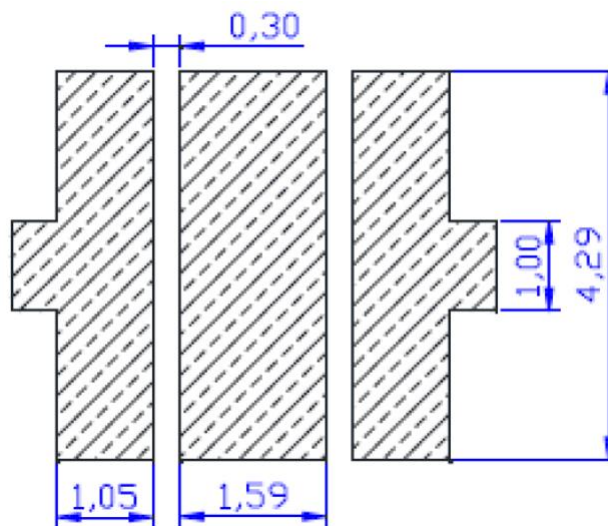

Figure 1. IN-C45PPATKU1 Recommended Solder Pattern

Note:

All dimensions are in millimeters.
Tolerance is ± 0.1 mm unless other specified.

Package Dimensions

(All dimensions are in mm, tolerance is ± 0.1 mm)

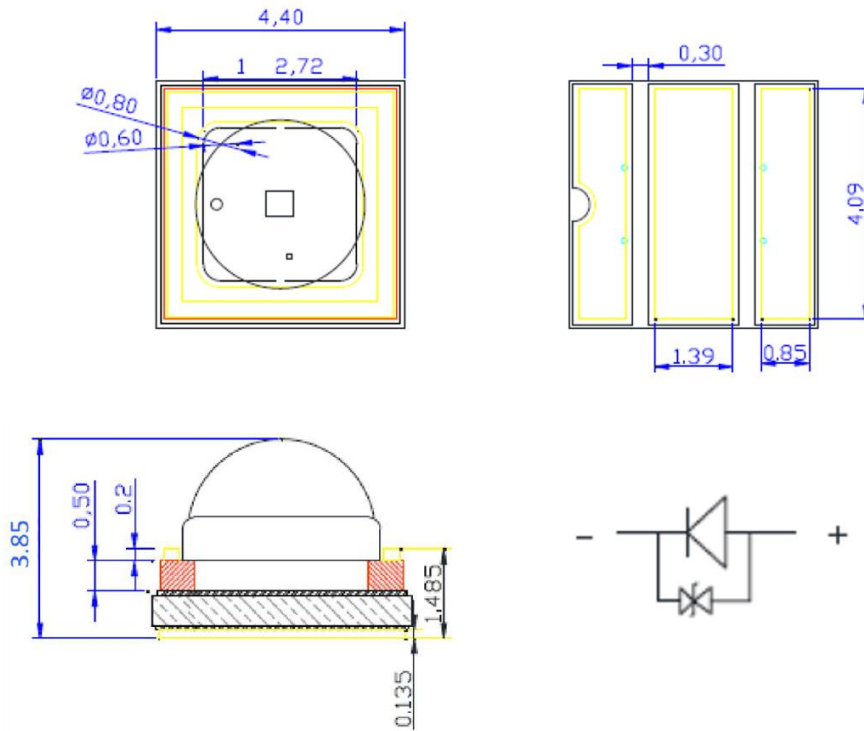

Figure 2. IN-C45PPATKU1 Package Dimension

Absolute Maximum Rating at 25°C

Characteristics	Symbol	Min.	Typical	Max.	Unit
DC Forward Current	IF		200		mA
Power Dissipation	Pd		1.4		W
Junction Temperature	Tj			60	°C
Reverse Voltage	VR		5.0		V
Storage Temperature Range	Tstg	-40	–	100	°C
Operating Temperature	Topr	-10	–	60	°C
Soldering Temperature	Tsol		260		°C

Notes:

1. Operating the LED beyond the listed maximum ratings may affect device reliability and cause permanent damage.
2. The LEDs are not designed to be driven in reverse bias.

Electronic-Optical Characteristics (Ambient Temp: 25°C)

Characteristics	Symbol	Min.	Typical	Max.	Unit
DC Forward Current	IF		150		mA
Forward Voltage	VF	5.0	6.0	7.0	V
Radiant Flux	Φ_e		20		mW
Peak Wavelength	λ_p	270	275	280	nm
Thermal Resistance	RTHJ-S		12.5		°C/W
Spectrum Half Width	$\Delta\lambda$		11		nm
Viewing Angle	2 $\theta_{1/2}$		30		Deg
Reverse Current	Ir			10	μ A

Note:

1. Forward Voltage (Vf): $\pm 0.1V$
2. Peak Wavelength(λ_p): $\pm 5.0nm$
3. Radiant Flux(Φ_e): $\pm 10\%$
4. Viewing angle(2 $\theta_{1/2}$) $\pm 10^\circ$

ESD Precaution

ATTENTION: Electrostatic Discharge (ESD) protection



The symbol above denotes that ESD precaution is needed. ESD protection for GaP and AlGaAs based chips is necessary even though they are relatively safe in the presence of low static-electric discharge. Parts built with AlInGaP, GaN, or/and InGaN based chips are STATIC SENSITIVE devices. ESD precaution must be taken during design and assembly. If manual work or processing is needed, please ensure the device is adequately protected from ESD during the process.

Please be advised that normal static precautions should be taken in the handling and assembly of this device to prevent damage or degradation which may be induced by electrostatic discharge (ESD).

Typical Characteristics Curves

Relative Spectral Power Distribution

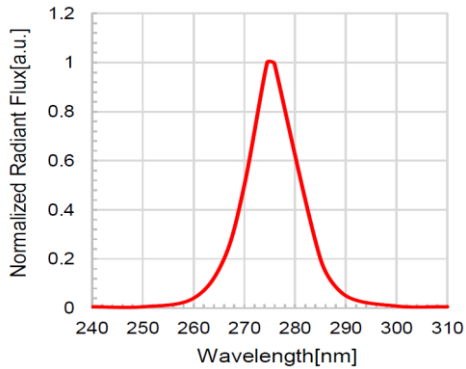

Forward Current vs. Forward Voltage (Ta=25°C)

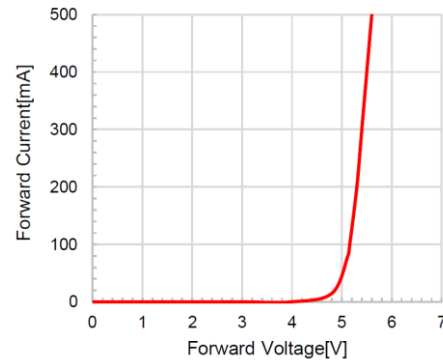

Relative Radiant Flux vs. Forward Current (Ta=25°C)

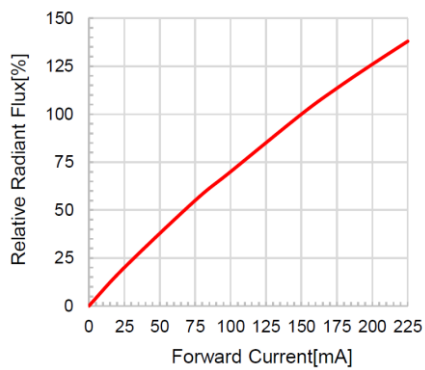

Peak wavelength Forward Current (Ta=25°C)

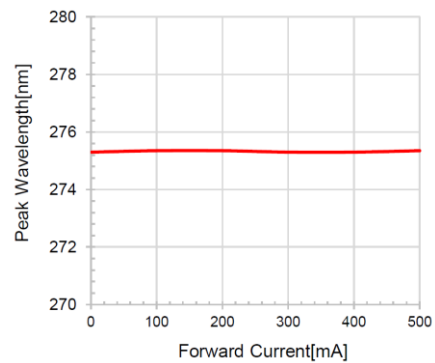

Derating

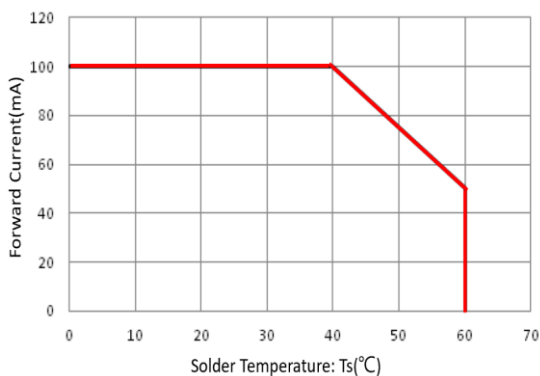

Radiation Characteristics

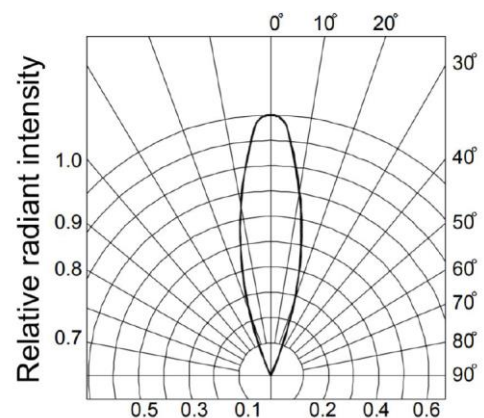

Notes:

Viewing angle (2θ1/2) ± 10°

Ordering Information

Peak Wavelength Range	Beam Angle	Forward Voltage(V)		Part Number
		Min	Max	
U1: 270~280nm	30°	5.0	7.0	IN-C45PPATKU1

Notes:

1. Forward voltage (VF) $\pm 0.5V$, Radiometric Power (Po) $\pm 15\%$.

Label Specifications

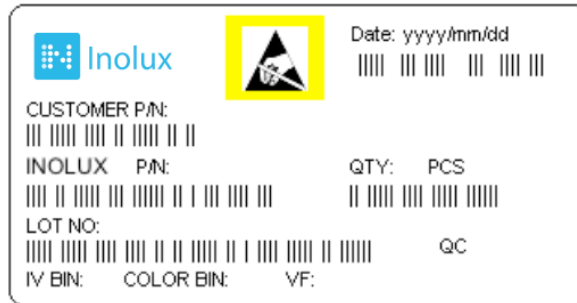

Inolux P/N:

I	N	-	C	4	5	PPA	T	K	U1	-	X	X	X	X
			Material	Package		Variation	Orientation	Current	Color		Customized Stamp-off			
Inolux	SMD		C = Ceramic Type	45PPA = 4.5 x 4.5, 30 Deg.			T = Top Mount	L=150mA	U1 = 270-280nm					

Lot No.:

Z	2	0	1	7	01	24	001
Internal Tracker	Year (2017, 2018,)				Month	Date	Serial

Forward Voltage Binning

		Voltage unit: V@150mA	
Peak Wavelength	Bin Code	Min	Max
U1 270nm-280nm	A	5.0	6.0
	B	6.0	7.0

Notes:

1. Binning current is 150 mA

Radiant flux (Power) binning

Bin Code (150mA)	Min. Po (mW)	Typ. Po (mW)
P1	-	20

Notes:

1. Binning current is 150mA

Peak wavelength binning reference table

Bin code (150mA)	Min. Wp (nm)	Max. Wp (nm)
W280	270.0	280.0

Notes:

1. Peak-wavelength (Wp) tolerance: ± 2.0 nm
2. Testing Current 150mA

Reflow Soldering

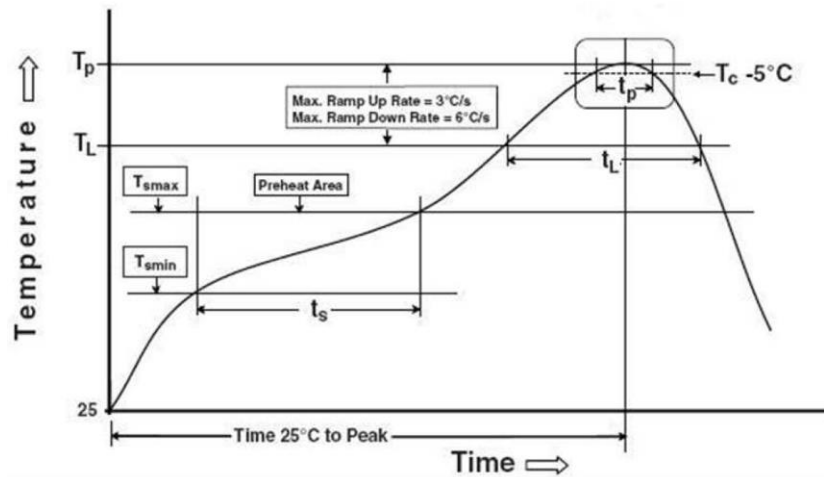

Profile Feature	Lead Free Assembly
Average Ramp-Up Rate (T_L to T_P)	3°C / second max
Preheat Temperature Min (T_{Smin})	150°C
Preheat Temperature Max (T_{Smax})	200°C
Preheat Time (t_s)	60 – 120 seconds
Time Maintained Above Temperature (T_L)	217°C
Time Maintained Above Time (t_L)	60 – 150 seconds
Peak / Classification Temperature (T_P)	260°C *
Time Within 5°C of Actual Peak Temperature (t_p)	10~30 seconds
Ramp – Down Rate (T_P to T_L)	6°C / second max
Time 25°C to Peak Temperature	8 minutes max

The recommended peak temperature is 245°C. The maximum soldering temperature should be controlled under 260°C

Soldering Iron

Basic Spec is ≤ 4 sec. when 260°C (+10°C \rightarrow -1 second). Power dissipation of Iron should be less than 15W. Surface temperature should be under 230°C

Rework

Rework should be completed within 4 second under 245°C

Packing

Reel

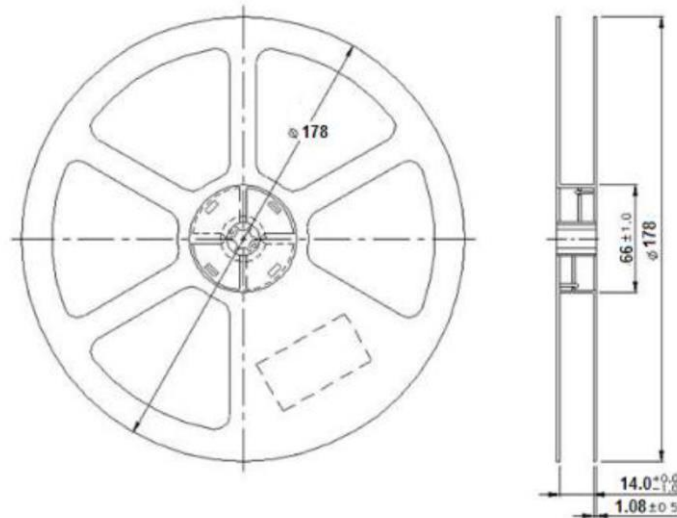

Tape

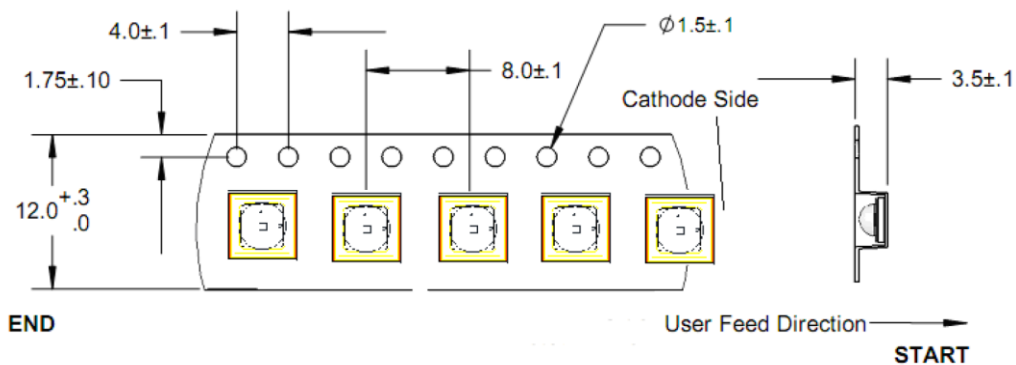

Notes:

1. Each Reel (minimum number of pieces is 100 and maximum is 500 (30D) is packed in a moisture-proof bag along with 2 packs of desiccant and a humidity indicator card.
2. Part No., Lot No., quantity should be indicated on the label of the moisture-proof bag and the cardboard box.

Precautions

1. Recommendation for using LEDs

1.1 The lens of LEDs should not be exposed to dust or debris. Excessive dust and debris may cause a drastic decrease in the luminosity.

1.2 Avoid mechanical stress on LED lens.

1.3 Do not touch the LED lens surface. It would affect the optical performance of the LED due to the LED lens' damage.

1.4 Pick & place tools are recommended for the remove of LEDs from the factory tape & reel packaging

2. Pick & place nozzle

The pickup tool was recommended and shown as below

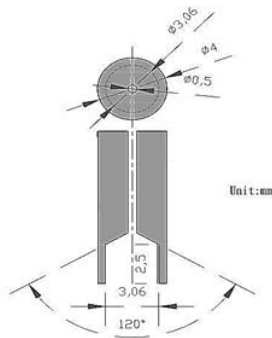

3. Lens handling

Please follow the guideline to pick LEDs

3.1 Use tweezers to pick LEDs

3.2 Do not touch the lens by using tweezers

3.3 Do not touch lens with fingers

3.4 Do not apply more than 4N of lens (400g) directly onto the lens

4. Lens cleaning

In the case which a small amount of dirt and dust particles remain on the lens surface, a suitable cleaning solution can be applied.

4.1 Try a gentle wiping with dust-free cloth.

4.2 If needed, use dust-free cloth and isopropyl alcohol to gently clean the dirt from the lens surface.

4.3 Do not use other solvents as they may directly react with the LED assembly

4.4 Do not use ultrasonic cleaning which will damage the LEDs

Revision History

Changes since last revision	Page	Version No.	Revision Date
Initial Release		1.0	03-19-2021

DISCLAIMER

INOLUX reserves the right to make changes without further notice to any products herein to improve reliability, function or design. INOLUX does not assume any liability arising out of the application or use of any product or circuit described herein; neither does it convey any license under its patent rights, nor the rights of others.

LIFE SUPPORT POLICY

INOLUX's products are not authorized for use as critical components in life support devices or systems without the express written approval of the President of INOLUX or INOLUX CORPORATION. As used herein:

1. Life support devices or systems are devices or systems which, (a) are intended for surgical implant into the body, or (b) support or sustain life, and (c) whose failure to perform when properly used in accordance with instructions for use provided in the labeling, can be reasonably expected to result in a significant injury of the user.
2. A critical component in any component of a life support device or system whose failure to perform can be reasonably expected to cause the failure of the life support device or system, or to affect its safety or effectiveness.