

## Inolux Surface Mount High Power Ultraviolet LED IN-5053PUV

Official Product	Product: IN-5053PUV		Data Sheet No.
Tentative Product	*****		IN-5053PUV
Specifications are subject to change without notice. Data and drawings herein are copyrighted.	Sept. 9, 2015	Version of 2.0	Page 1/12

<b>DISCLAIMER</b> .....	<b>3</b>
<b>LABEL SPECIFICATIONS</b> .....	<b>4</b>
<b>PRODUCT CHARACTERISTICS</b> .....	<b>5</b>
<b>ABSOLUTE MAXIMUM RATINGS</b> .....	<b>5</b>
<b>ELECTRO-OPTICAL CHARACTERISTICS@150MA</b> .....	<b>6</b>
<b>PACKAGE OUTLINE DIMENSION</b> .....	<b>7</b>
<b>RECOMMENDED SOLDERING PATTERN FOR REFLOW SOLDERING</b> .....	<b>7</b>
<b>CHARACTERISTIC CURVES</b> .....	<b>8</b>
<b>THERMAL DESIGN</b> .....	<b>9</b>
<b>PACKING INFORMATION</b> .....	<b>11</b>
<b>REVISION HISTORY</b> .....	<b>12</b>

Official Product	Product: IN-5053PUV		Data Sheet No.
Tentative Product	*****		IN-5053PUV
Specifications are subject to change without notice. Data and drawings herein are copyrighted.	Sept. 9, 2015	Version of 2.0	Page 2/12

## DISCLAIMER

INOLUX reserves the right to make changes without further notice to any products herein to improve reliability, function or design. INOLUX does not assume any liability arising out of the application or use of any product or circuit described herein; neither does it convey any license under its patent rights, nor the rights of others.

## LIFE SUPPORT POLICY

INOLUX's products are not authorized for use as critical components in life support devices or systems without the express written approval of the President of INOLUX or INOLUX CORPORATION. As used herein:

1. Life support devices or systems are devices or systems which, (a) are intended for surgical implant into the body, or (b) support or sustain life, and (c) whose failure to perform when properly used in accordance with instructions for use provided in the labeling, can be reasonably expected to result in a significant injury of the user.
2. A critical component in any component of a life support device or system whose failure to perform can be reasonably expected to cause the failure of the life support device or system, or to affect its safety or effectiveness.

Official Product	Product: IN-5053PUV		Data Sheet No.
Tentative Product	*****		IN-5053PUV
Specifications are subject to change without notice. Data and drawings herein are copyrighted.	Sept. 9, 2015	Version of 2.0	Page 3/12

**Label Specifications**

INOLUX P/N:

**I N - 5 0 5 3 P U V - X X X X**

↓	↓	↓
Series Name	Substrate / Emitting Color	Customer Code
IN-5053 Inolux 5053 package	5050 3 chip PLCC UV@380-420nm	XXXX Customer Product Code

**Lot No.:**

1	2	3	4	5	6	7	8	9	10
<b>E</b>	<b>1</b>	<b>A</b>	<b>1</b>	<b>A</b>	<b>2</b>	<b>2</b>	<b>L</b>	<b>1</b>	<b>2</b>
Code 1 2		Code 3	Code 4	Code 5	Code 6	Code 7	Code 8	Code 9	Code 10
		Mfg. Year	Mfg. Month	Mfg. Date	Consecutive number		Special code		
Internal Tracing Code		2010-A 2011-B 2012-C 2013-D . .	1:Jan. 2:Feb. ... A:Oct. B:Nov. C:Dec.	1:A 2:B 3:C ... 26:Z 27:7 28:8 29:9 30:3 31:4	01~ZZ		000~ZZZ		

Official Product	Product: IN-5053PUV	Data Sheet No.
Tentative Product	*****	IN-5053PUV
Specifications are subject to change without notice. Data and drawings herein are copyrighted.	Sept. 9, 2015	Version of 2.0
		Page 4/12

**Product Characteristics**

**Absolute Maximum Ratings**

(T<sub>j</sub> = 25 °C)

Parameter	Rating
DC Forward Current (mA)	150mA
LED Junction Temperature	125°C
LED Operating Temperature	-40°C ~ 110°C
Storage Temperature	-40°C ~ 110°C
Soldering Temperature	Max. 260°C / Max. 10 sec. (JEDEC 020c)
Preconditioning	Acc. to JEDEC Level 3

Official Product	Product: IN-5053PUV	Data Sheet No.
Tentative Product	*****	IN-5053PUV
Specifications are subject to change without notice. Data and drawings herein are copyrighted.	Sept. 9, 2015	Version of 2.0
		Page 5/12

**Electro-Optical Characteristics@150mA**

(T<sub>j</sub> 25 °C)

Part Number	Color	Group	Minimum Radiometric Power (mW)		Vf	
					Min	Max
IN-5053PUV	U40 (380~390nm)	PB3	85	100	3.0	4.0
		PC1	100	120	3.0	4.0
		PC2	120	140	3.0	4.0
	U50 (390~400nm)	PB3	85	100	3.0	4.0
		PC1	100	120	3.0	4.0
		PC2	120	140	3.0	4.0
	U60 (400~410nm)	PB3	85	100	3.0	4.0
		PC1	100	120	3.0	4.0
		PC2	120	140	3.0	4.0
	U40 (410~420nm)	PB3	85	100	3.0	4.0
		PC1	100	120	3.0	4.0
		PC2	120	140	3.0	4.0

Notes:

1. Radiometric power is measured with an accuracy of ±10%
2. The forward voltage is measured with an accuracy of ±0.2V

Official Product	Product: IN-5053PUV	Data Sheet No.	
Tentative Product	*****	IN-5053PUV	
Specifications are subject to change without notice. Data and drawings herein are copyrighted.	Sept. 9, 2015	Version of 2.0	Page 6/12

**Package Outline Dimension**

**Recommended Soldering Pattern for Reflow Soldering**

Unit: mm Tolerance: +/-0.2

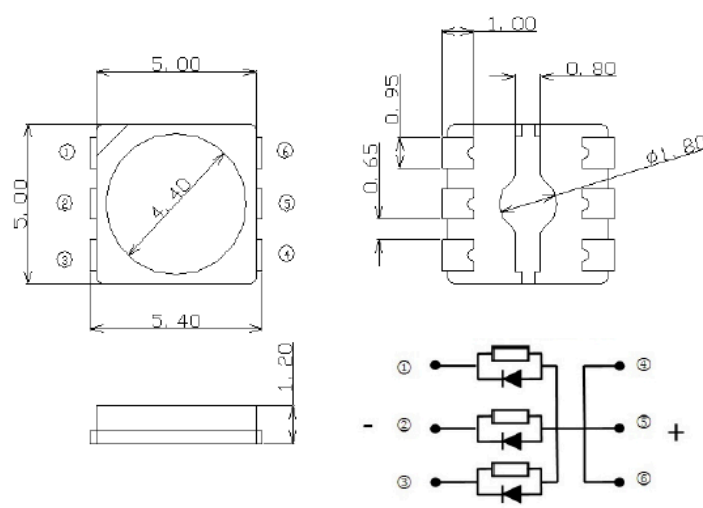
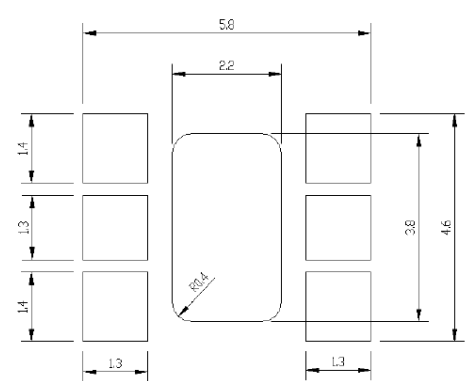
Outline Dimension	Solder Pattern
	
<p>Soldering terminals may shift in the x, y direction.</p>	<p>Unit: mm</p>

Notes:

1. Drawings are not to scale
2. All dimensions are in millimeter
3. The polarity of die heat sink at bottom is Anode

Official Product	Product: IN-5053PUV	Data Sheet No.
Tentative Product	*****	IN-5053PUV
Specifications are subject to change without notice. Data and drawings herein are copyrighted.	Sept. 9, 2015	Version of 2.0 Page 7/12

**Characteristic Curves**

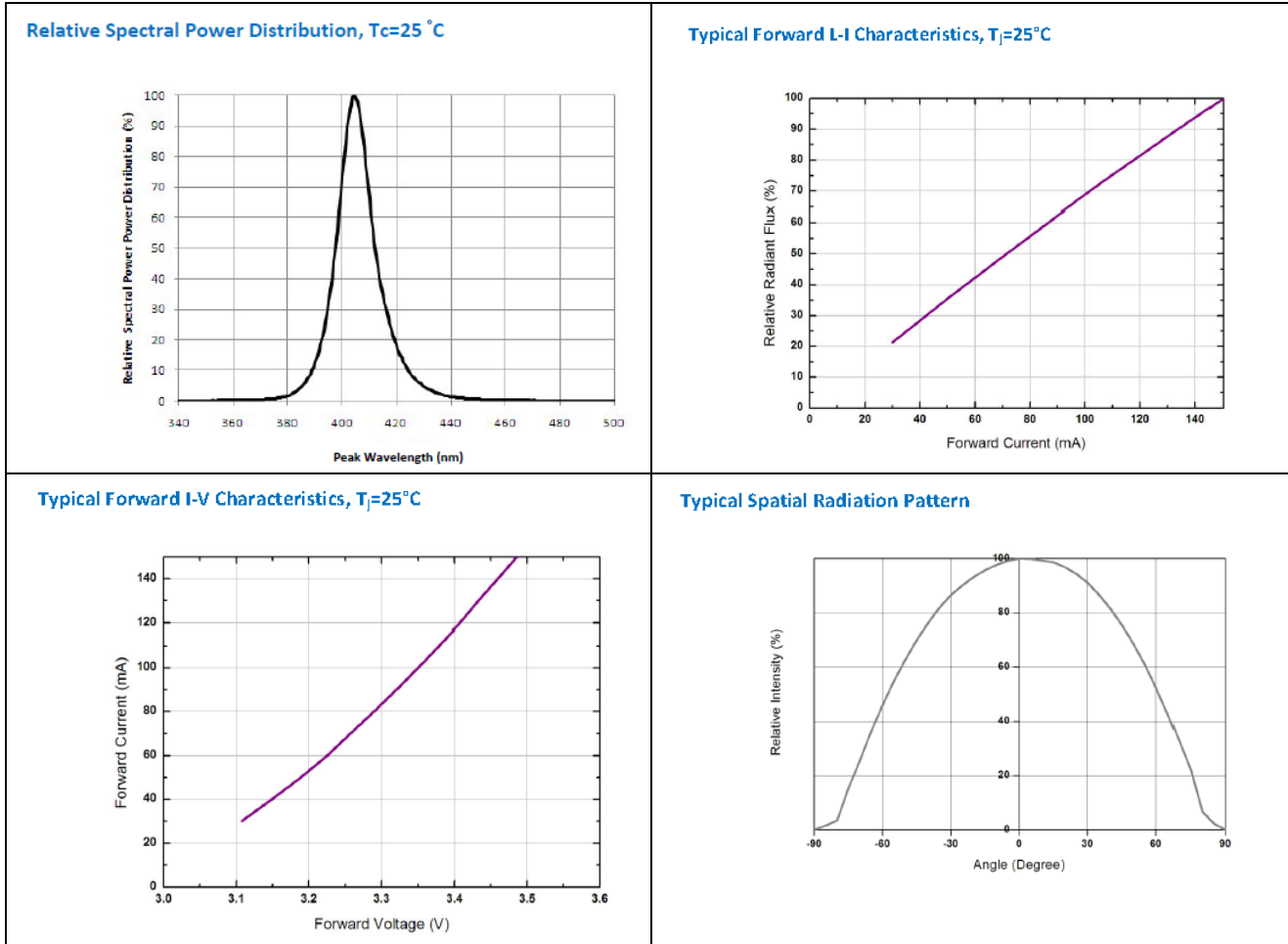

Official Product	Product: IN-5053PUV	Data Sheet No.
Tentative Product	*****	IN-5053PUV
Specifications are subject to change without notice. Data and drawings herein are copyrighted.	Sept. 9, 2015	Version of 2.0
		Page 8/12



## Thermal Design

Thermal design of the end product is important. The thermal resistance between the junction and the solder point (R<sub>ΘJ-S</sub>) and the end product should be designed to minimize the thermal resistance from the solder point to ambient in order to optimize the emitter life and optical characteristics. The maximum operation current is determined by the plot of Allowable Forward Current vs. Ambient Temperature.

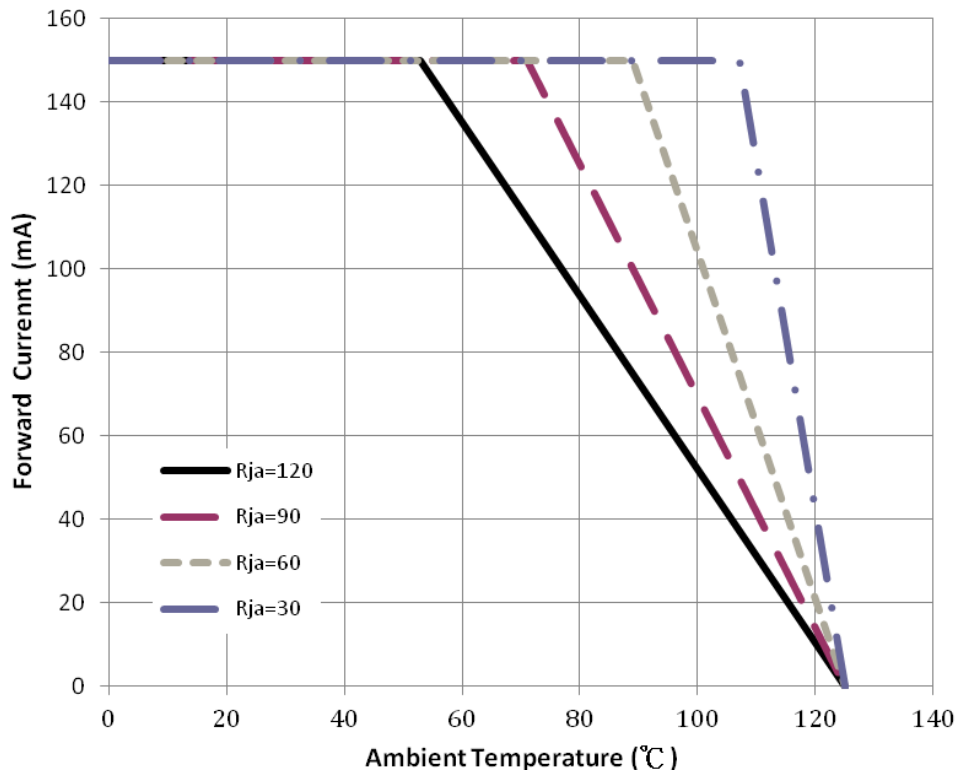

The junction temperature can be correlated to the thermal resistance between the junction and ambient (R<sub>ja</sub>) by the following equation.

$$T_j = T_a + R_{ja} * W$$

T<sub>j</sub>: LED junction temperature

T<sub>a</sub>: Ambient temperature

R<sub>ja</sub>: Thermal resistance between the junction and ambient

W: Input power (I<sub>F</sub>\*V<sub>F</sub>)

Official Product	Product: IN-5053PUV	Data Sheet No.	
Tentative Product	*****	IN-5053PUV	
Specifications are subject to change without notice. Data and drawings herein are copyrighted.	Sept. 9, 2015	Version of 2.0	Page 9/12

### Reflow Soldering

The LEDs can be soldered using the parameter listed below. As a general guideline, the users are suggested to follow the recommended soldering profile provided by the manufacturer of the solder paste. Although the recommended soldering conditions are specified in the list, reflow soldering at the lowest possible temperature is preferred for the LEDs.

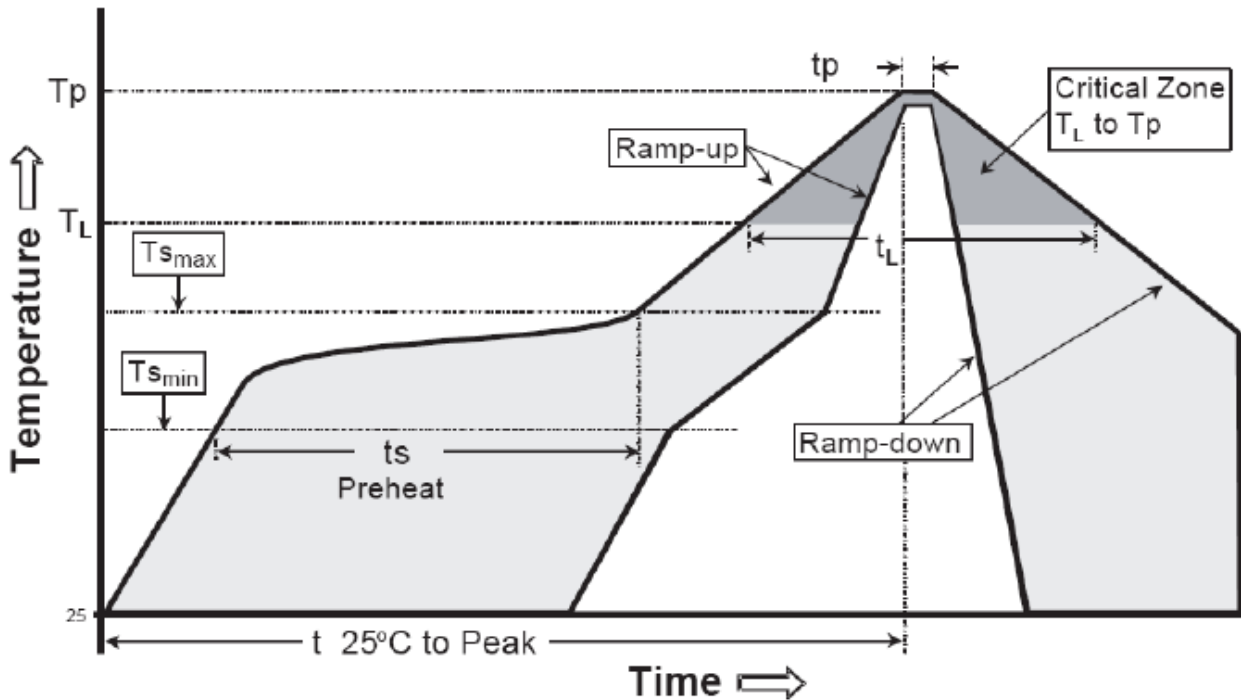

Profile Feature	Sn-Pb Eutectic Assembly	Pb-Free Assembly
Average Ramp-up Rate (Ts <sub>max</sub> to Tp)	3°C/second max.	3°C/second max.
Preheat		
- Temperature Min(Ts <sub>min</sub> )	100°C	150°C
- Temperature Max(Ts <sub>max</sub> )	150°C	200°C
- Time(ts <sub>min</sub> to ts <sub>max</sub> )	60-120 seconds	60-180 seconds
Time maintained above:		
- Temperature(T <sub>L</sub> )	183°C	217°C
- Time(t <sub>L</sub> )	60-150 seconds	60-150 seconds
Peak/classification Temperature(T <sub>p</sub> )	215°C	260°C
Time within 5°C of actual Peak Temperature(t <sub>p</sub> )	10-30 seconds	20-40 seconds
Ramp-Down Rate	6°C/second max.	6°C/second max.
Time 25°C to Peak Temperature	6 minutes max.	8 minutes max.

Official Product	Product: IN-5053PUV	Data Sheet No.	
Tentative Product	*****	IN-5053PUV	
Specifications are subject to change without notice. Data and drawings herein are copyrighted.	Sept. 9, 2015	Version of 2.0	Page 10/12

### Packing Information

Carrier Tape

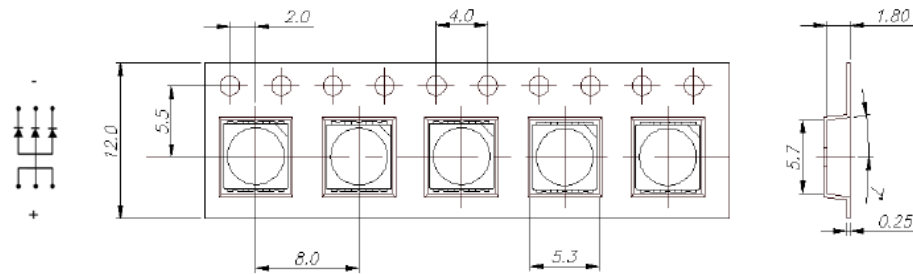

Reel Dimension

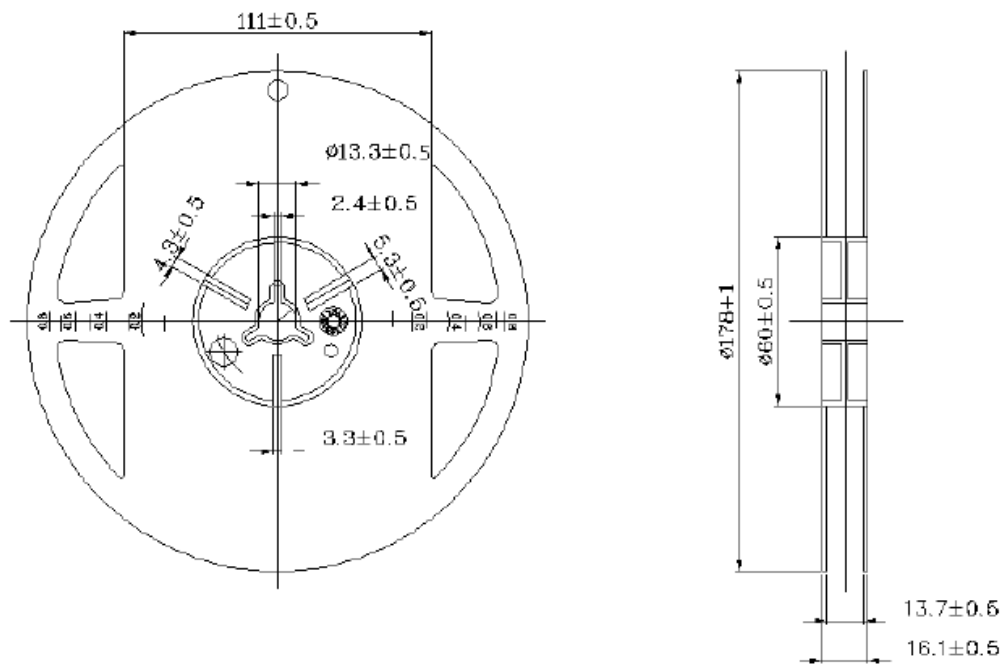

Note : All Dimensions are in millimeter

Official Product	Product: IN-5053PUV	Data Sheet No.
Tentative Product	*****	IN-5053PUV
Specifications are subject to change without notice. Data and drawings herein are copyrighted.	Sept. 9, 2015	Version of 2.0
		Page 11/12

**Revision History**

Changes since last revision	Page	Version No.	Revision Date
Initial release		1.0	04-21-2014
Format Update		2.0	09-09-2015

Official Product	Product: IN-5053PUV		Data Sheet No.
Tentative Product	*****		IN-5053PUV
Specifications are subject to change without notice. Data and drawings herein are copyrighted.	Sept. 9, 2015	Version of 2.0	Page 12/12