

Features

- 5mm Bi-Color Through hole
- 2 leads, 8.6mm lens height
- White diffused lens
- Special packaging available upon request
- High reliability

Description

The INL-5DB3UYYGP70 is Bi-Color through-hole lamp. It is a 5mm epoxy type LED which can be used in various applications.

Applications

- Consumer Electronics
- Variable Message Signs (VMS)
- Automobile After Market
- Industrial Equipment
- Advertising Signs

Package Dimensions in mm

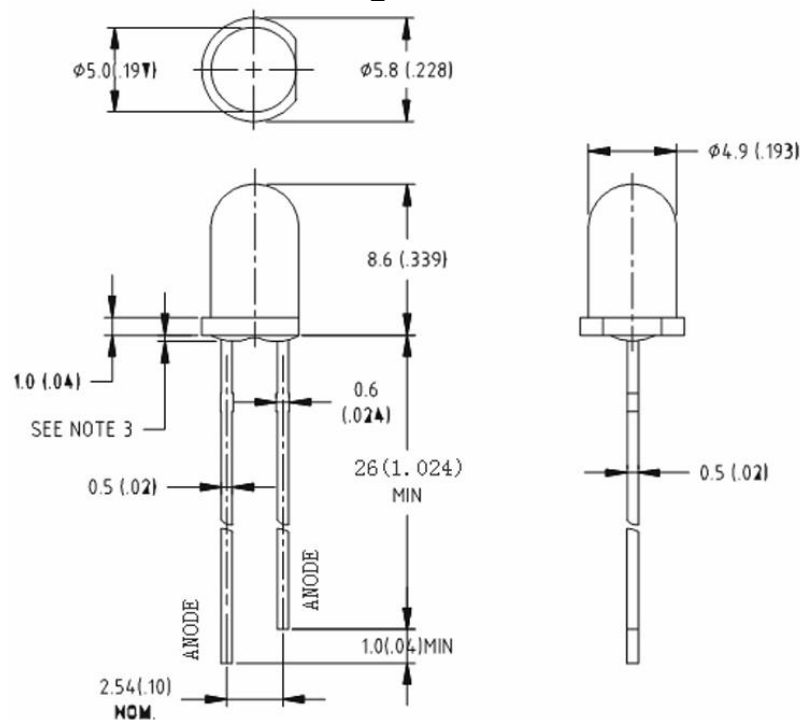

Figure 1. INL-5DB3UYYGP70 Package Dimensions

Notes:

1. All dimensions are in millimeters (inches).
2. Tolerance is ± 0.25 mm (.010 ") unless otherwise noted.
3. Protruded resin under flange is 1.00mm (0.39") max.

Absolute Maximum Rating at 25°C (Note 1)

Product	Emission Color	Pd (mW)	IF (mA)	IFP* (mA)	VR (V)	TOP (°C)	TST (°C)
INL-5DB3UYYGP70	Yellow	78	30	100	5	-40°C ~+80°C	-40°C ~+85°C
	Yellow Green						

Notes

1. Condition for IFP is pulse of 1/10 duty and 0.1msec width

Electrical Characteristics $T_A = 25^\circ\text{C}$ (Note 1)

Product	Emission Color	I _F (mA)	V _F (V)		λ(nm)			Viewing Angle	I _V [*] (mcd)	
			min	max	λ _D	λ _P	Δλ	2θ 1/2	min	typ.
INL-5DB3UYYGP70	Yellow	10	1.6	2.4	590	590	15	70	1.0	2.0
	Yellow Green	10	1.6	2.4	570	565	20		1.0	2.0

Notes 1. Performance guaranteed only under conditions listed in above tables.

ESD Precaution

ATTENTION: Electrostatic Discharge (ESD) protection



The symbol above denotes that ESD precaution is needed. ESD protection for GaP and AlGaAs based chips is necessary even though they are relatively safe in the presence of low static-electric discharge. Parts built with AlInGaP, GaN, or/and InGaN based chips are STATIC SENSITIVE devices. ESD precaution must be taken during design and assembly.

If manual work or processing is needed, please ensure the device is adequately protected from ESD during the process.

Please be advised that normal static precautions should be taken in the handling and assembly of this device to prevent damage or degradation which may be induced by electrostatic discharge (ESD).

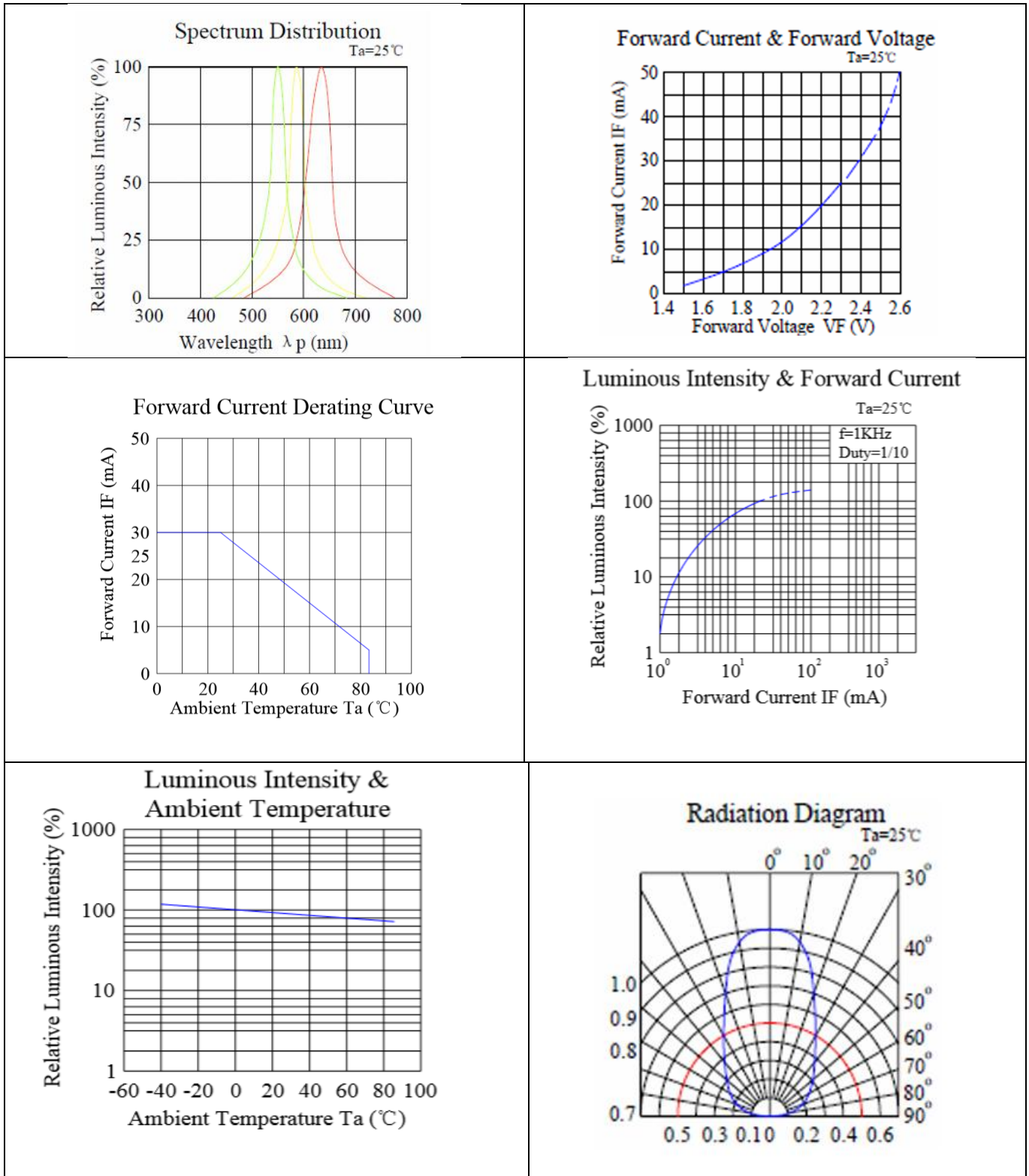
Typical Characteristic Curves-Yellow and Yellow Green

Ordering Information

Product	Emission Color	Test Current I _F (mA)	Luminous Intensity I _v (mcd) (Typ.)	Forward Voltage V _F (V) (Typ.)	Orderable Part Number
INL-5DB3UYYGP70	Yellow	10	2.0	2.0	INL-5DB3UYYGP70
	Yellow Green	10	2.0	2.0	

Label Specifications

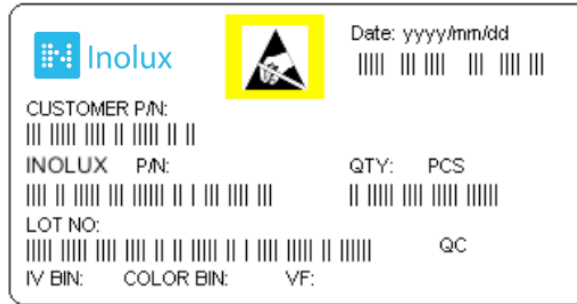

Inolux P/N:

I	N	L	-	5	DB	3	U	YYG	P	70	-	X	X	X	X
				Material	Lead Number	Lens	Color	Chip Type	View Angle	Customized Stamp-off					
Inolux Through Hole Lamp				5DB = Standard 8.6mm dual chip	3 = 3 leads	3U = Diffused Lens	Y = 590nm YG=570nm	P = GaP	70 = 70 deg.						

Lot No.:

Z	2	0	1	7	01	24	001
Internal Tracker	Year (2017, 2018,)				Month	Date	Serial

Reliability

Item	Frequency/ lots/ samples/ failures	Standards Reference	Conditions
Precondition	For all reliability monitoring tests according to JEDEC Level 2	J-STD-020	1.) Baking at 85°C for 24hrs 2.) Moisture storage at 85°C/ 60% R.H. for 168hrs
Solderability	1Q/ 1/ 22/ 0	JESD22-B102-B And CNS-5068	Accelerated aging 155°C/ 24hrs Tinning speed: 2.5+0.5cm/s Tinning: A: 215°C/ 3+1s or B: 260°C/ 10+1s
Resistance to soldering heat		CNS-5067	Dipping soldering terminal only Soldering bath temperature A: 260+/-5°C; 10+/-1s B: 350+/-10°C; 3+/-0.5s
Operating life test	1Q/ 1/ 40/ 0	CNS-11829	1.) Precondition: 85°C baking for 24hrs 85°C/ 60%R.H. for 168hrs 2.) Tamb25°C; IF=20mA; duration 1000hrs
High humidity, high temperature bias	1Q/ 1/ 45/ 0	JESD-A101-B	Tamb: 85°C Humidity: 85% R.H., IF=5mA Duration: 1000hrs
High temperature bias	1Q/ 1/ 20	IN specs.	Tamb: 55°C IF=20mA Duration: 1000hrs
Pulse life test	1Q/ 1/ 40/ 0		Tamb25°C, If=20mA,, Ip=100mA, Duty cycle=0.125 (tp=125 μs, T=1sec) Duration 500hrs)
Temperature cycle	1Q/ 1/ 76/ 0	JESD-A104-A IEC 68-2-14, Nb	A cycle: -40 degree C 15min; +85 degree C 15min Thermal steady within 5 min.. 300 cycles 2 chamber/ Air-to-air type
High humidity storage test	1Q/ 1/ 40/ 0	CNS-6117	60+3°C 90+5/-10% R.H. for 500hrs
High temperature storage test	1Q/ 1/ 40/ 0	CNS-554	100+10°C for 500hrs
Low temperature storage test	1Q/ 1/ 40/ 0	CNS-6118	-40+5°C for 500hrs

Revision History

Changes since last revision	Page	Version No.	Revision Date
Initial Release		1.0	05-12-2026

DISCLAIMER

INOLUX reserves the right to make changes without further notice to any products herein to improve reliability, function or design. INOLUX does not assume any liability arising out of the application or use of any product or circuit described herein; neither does it convey any license under its patent rights, nor the rights of others.

LIFE SUPPORT POLICY

INOLUX's products are not authorized for use as critical components in life support devices or systems without the express written approval of the President of INOLUX or INOLUX CORPORATION. As used herein:

1. Life support devices or systems are devices or systems which, (a) are intended for surgical implant into the body, or (b) support or sustain life, and (c) whose failure to perform when properly used in accordance with instructions for use provided in the labeling, can be reasonably expected to result in a significant injury of the user.
2. A critical component in any component of a life support device or system whose failure to perform can be reasonably expected to cause the failure of the life support device or system, or to affect its safety or effectiveness.