

Features

- 2427 with integrated high quality constant current IC and RGB LED chip.
- Built-in IC, with high precision of constant current and internal RGB chips spectral processing in advance.
- Single line data transmission (return to zero code).
- Specific Shaping Transmit Technology - number of LED stacked is not restricted.
- Cascading Enhancement Technology - any 2 LED spacing can be up to 10 meters
- Data transfer rate of 750 kbp/s at 30 frames per second.
- RGB output port PWM control can achieve 256 grey level adjustments.
- Upon powering up, IC performs self-inspection then lights connection on the pin B lamp.
- SA-I Anti-interference patent technology for single line data transmission.
- Built-in power supply reverse connect protection module, reversed power input will not damage the IC.

Description

The IN-PI22TAT5R5G5B is 2.4*2.7*1.1mm RGB LED with integrated IC. It is a SMD type LED which can be used in various applications.

Applications

- Full color LED string light
- LED full color module
- LED guardrail tube
- LED scene lighting
- LED point light
- LED pixel screen
- LED shaped screen

Package Outline Dimensions & Pin Configuration

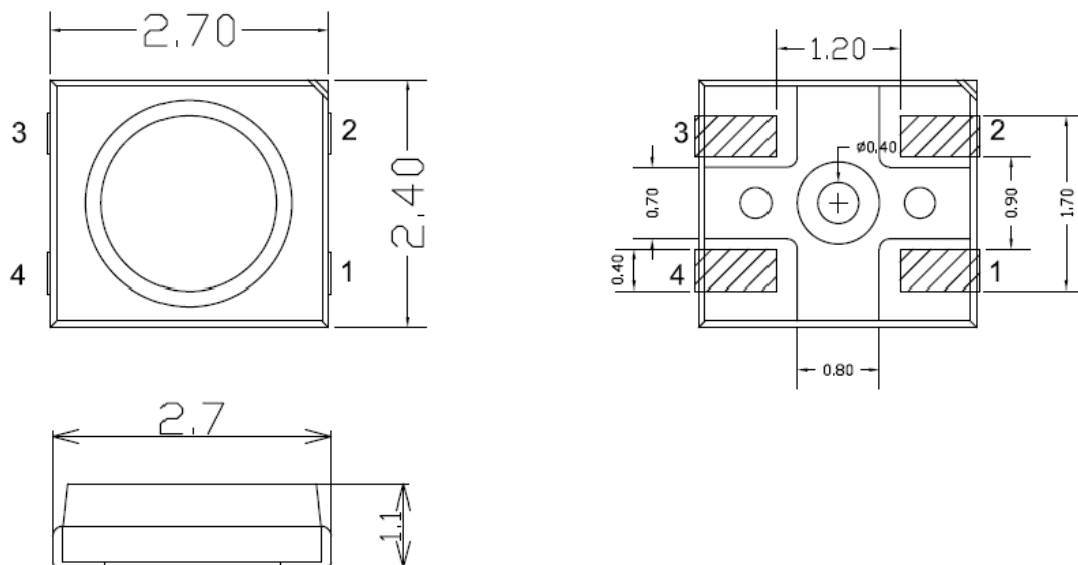

Figure 1. IN-PI22TAT5R5G5B Package Outline Dimensions

Pin Configuration

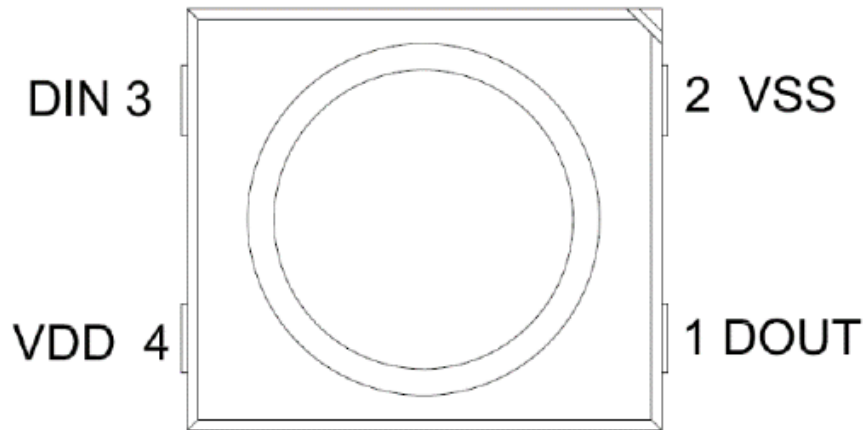

Figure 2. IN- PI22TAT5R5G5B Pin Configuration

Notes:

1. Dimension in millimeter, tolerance is $\pm 0.1\text{mm}$ unless otherwise noted.

Number	Symbol	Function Description
1	DOUT	Control data signal output
2	VSS	Ground
3	DIN	Control data signal input
4	VDD	Power supply LED

Soldering Pad Size

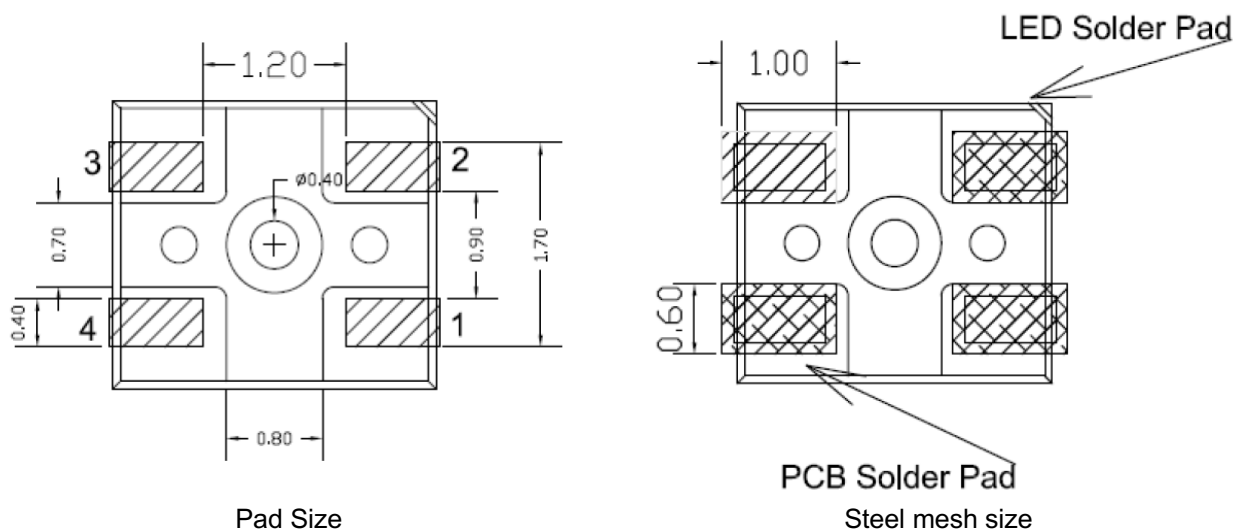

Absolute Maximum Rating ($T_a = 25\text{ }^\circ\text{C}$, $V_{SS}=0\text{V}$)

Parameter	Symbol	Range	Unit
Power supply voltage	V_{DD}	+3.5~+5.5	V
Logic input voltage	V_{IN}	-0.5 ~VDD+0.5	V
Working temperature	T_{OPT}	-45 ~ +85	$^\circ\text{C}$
Storage temperature	T_{STG}	-50 ~ +150	$^\circ\text{C}$
ESD pressure(HBM)	V_{ESD}	4K	V
ESD pressure(DM)	V_{ESD}	200	V

LED Characteristics ($T_A = 25^\circ\text{C}$)

Color	5mA	
	Wavelength(nm)	Light Intensity(mcd)
Red	620-630	100-200
Green	520-535	400-700
Blue	460-475	50-100

Recommended Operating Ranges (unless otherwise specified, $T_A = -20 \sim +70 \text{ }^\circ\text{C}$, $V_{DD} = 4.5 \sim 5.5\text{V}$, $V_{SS} = 0\text{V}$)

Parameter	Symbol	Min.	Typ.	Max	Unit	Test conditions
Supply voltage	V_{DD}	-	5.2	-	V	-
R/G/B port pressure	$V_{DS, MAX}$	-	-	26	V	-
DOUT drive capability	I_{DOH}	-	49	-	mA	DOUT connect ground, the maximum drive current
DOUT drive capability	I_{DOL}	-	-50	-	mA	DOUT connect +, the largest current
The signal input flip threshold	V_{IH}	3.4	-	-	V	$V_{DD} = 5.0\text{V}$
The signal input flip threshold	V_{IL}	-	-	1.6	V	$V_{DD} = 5.0\text{V}$
The frequency of PWM	F_{PWM}	-	1.2	-	KHZ	-
Static power consumption	I_{DD}	-	1	-	mA	-

Switching Characteristics *(unless otherwise specified, Ta=25 °C)*

Parameter	Symbol	Min.	Typ.	Max	Unit	Test conditions
The speed of data transmission	f_{DIN}	-	800	-	KHZ	The duty ratio of 67% (data 1)
DOOUT transmission delay	T_{PLH}	-	-	500	ns	DIN→DOOUT
	T_{PHL}	-	-	500	ns	
I_{OUT} Rise/Drop Time	T_r	-	100	-	ns	VDS=1.5 VIOUT=13mA
	T_f	-	100	-	ns	

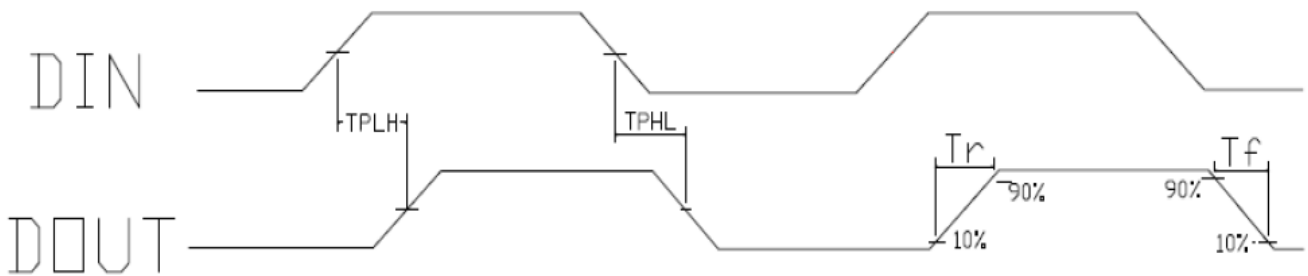

Timing Waveforms

1. Input Code

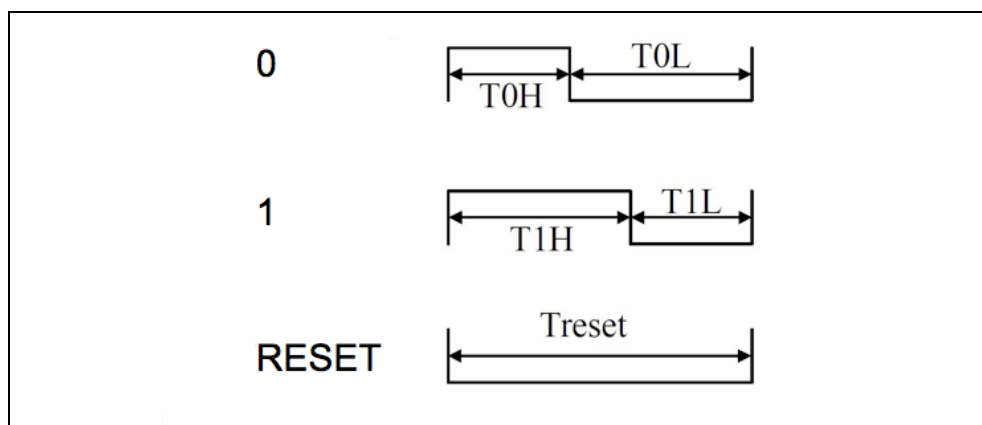

2. The data transmission time ($T_H+T_L=1.25\mu s\pm 600ns$):

Name	Description	Typ. value	error
T0H	0 code, high level time	0.3 μs	$\pm 0.15\mu s$
T0L	0 code, low level time	0.9 μs	$\pm 0.15\mu s$
T1H	1 code, high level time	0.9 μs	$\pm 0.15\mu s$
T1L	1 code, low level time	0.3 μs	$\pm 0.15\mu s$
Trst	Reset code, low level time	80 μs	

3. Connection Mode

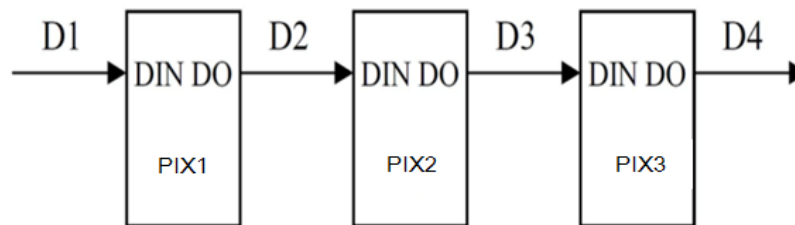

4. The method of data transmission

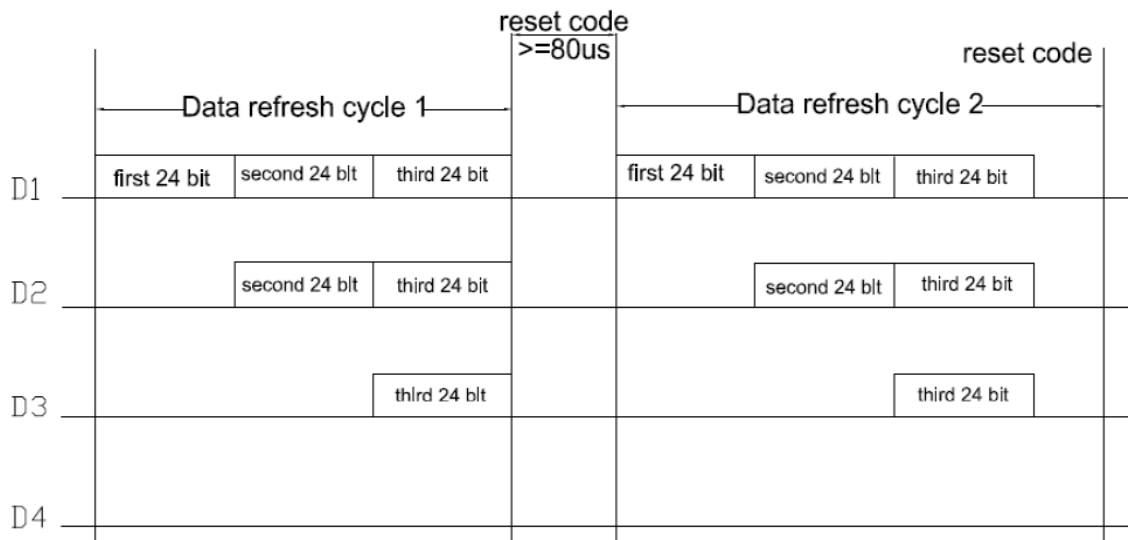

Note: the D1 sends data for MCU, D2, D3, D4 for data forwarding automatic shaping cascade circuit.

5. 24-bit data format

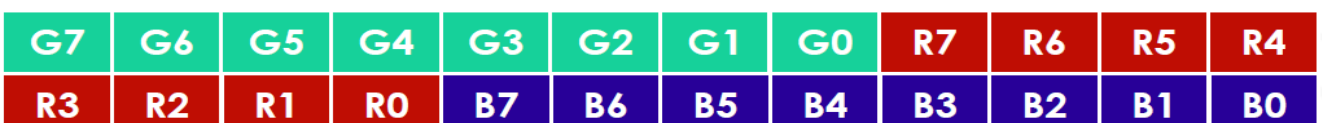

Note: high starting, in order to send data (G7 - G6 -B0)

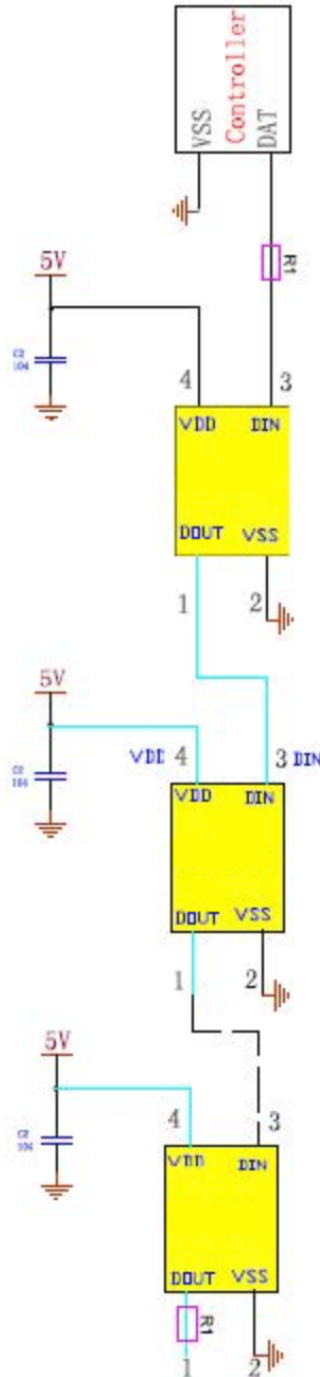
Typical Application Circuit

Product signal input and output must be connected in series with protection resistor R1. R1 depends on the size of the cascade amount, the greater the number of cascades, the smaller R1. The general recommended value is between 200-2K Ω , usually the recommended value is typical 500 Ω .

LED Performance Graph

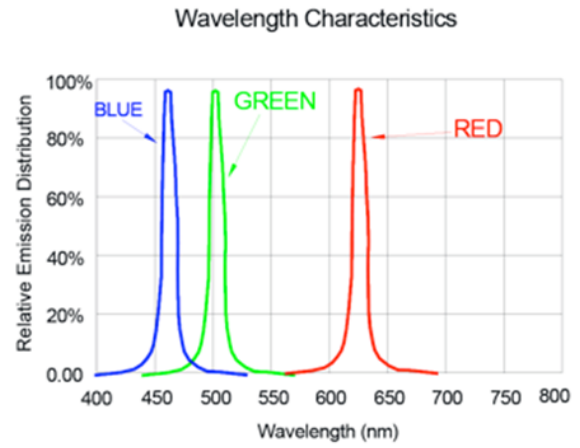
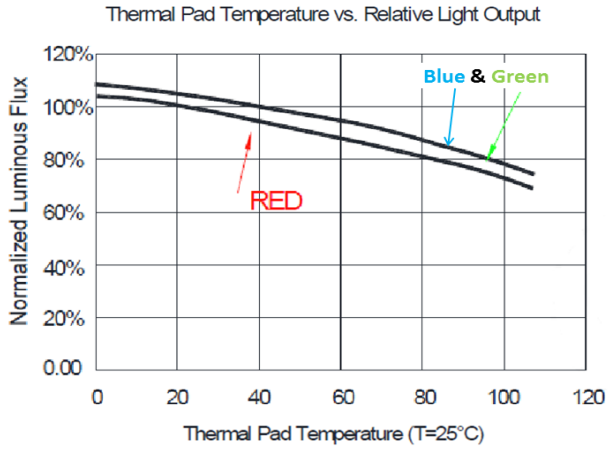

Typical Radiation Pattern 120°

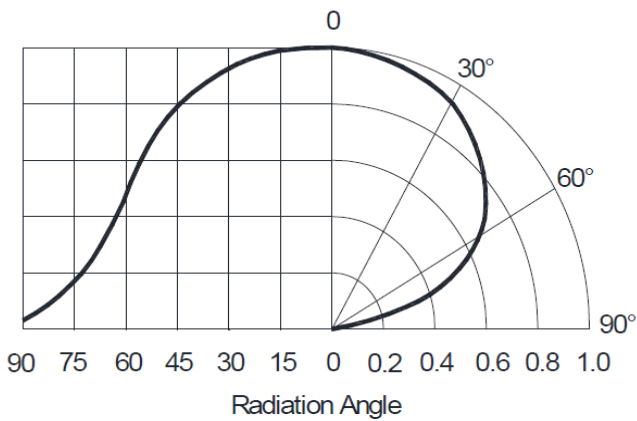

Ordering Information

Product	Emission Color	IV(mcd)	Orderable Part Number
IN-PI22TAT5R5G5B	R	100-200	IN-PI22TAT5R5G5B
	G	400-700	
	B	50-100	

Label Specifications

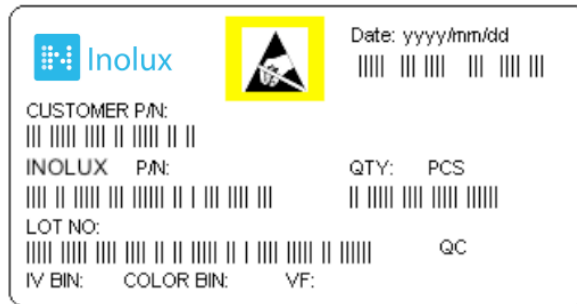

Inolux P/N:

I	N	PI	-	22	T	A	T	(X)	R	(X)	G	(X)	B	-	X	X	X	X
		Product		Package	Die Qty.	Variation	Orientation	Current	Color	Current	Color	Current	Color		Customized Stamp-off			
Inolux		PI- Single trace IC PC- Clock Function IC		22TA = 24 x 27 x 1.1 mm			T = Top Mount	P=12mA 5 = 5mA	R = 624 nm	P=12mA 5 = 5mA	G = 520 nm	P=12mA 5 = 5mA	B = 470 nm					

Lot No.:

Z	2	0	1	7	01	24	001
Internal Tracker	Year (2017, 2018,)				Month	Date	Serial

Precautions

Please read the following notes before using the product:

1. Storage

- 1.1 Do not open moisture proof bag before the products are ready to use.
- 1.2 Before opening the package, the LEDs should be kept at 30°C or less and 80%RH or less.
- 1.3 The LEDs should be used within a year.
- 1.4 After opening the package, the remaining LEDs should be kept in a resealed bag.
- 1.5 The LEDs require mandatory baking before usage. Baking treatment listed below.
- 1.6 If the moisture adsorbent material has fabled away or the LEDs have exceeded the storage time, baking treatment should be performed using the following conditions.

*Baking treatment: 60±5°C for 24 hours.

2. Soldering Condition

Recommended soldering conditions:

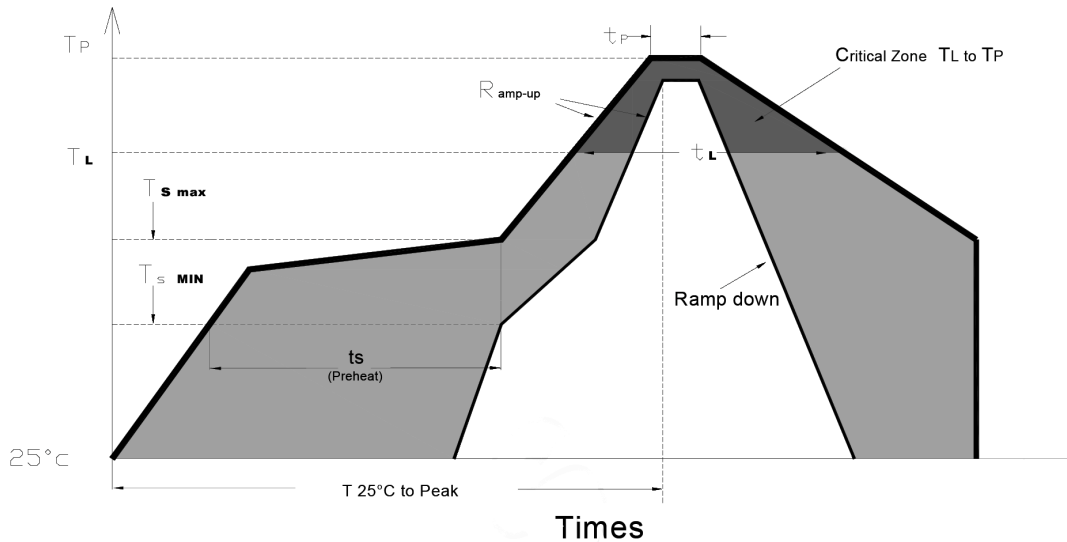

Profile Feature	Lead-Free Solder
Average Ramp-Up Rate ($T_{s \max}$ to T_p)	3°C/second max.
Preheat: Temperature Min ($T_{s \min}$)	150°C
Preheat: Temperature Min ($T_{s \max}$)	200°C
Preheat: Time ($t_{s \min}$ to $t_{s \max}$)	60-180 seconds
Time Maintained Above: Temperature (T_L)	217 °C
Time Maintained Above: Time (t_L)	60-150 seconds
Peak/Classification Temperature (T_p)	240 °C
Time Within 5°C of Actual Peak Temperature (t_p)	<10 seconds
Ramp-Down Rate	6°C/second max.
Time 25 °C to Peak Temperature	<6 minutes max.

Note: Excessive soldering temperature and / or time might result in deformation of the LED lens or catastrophic failure of the LED.

3. Soldering Iron

Each terminal is to go to the tip of soldering iron temperature less than 260°C for 5 seconds within once in less than the soldering iron capacity 25W. Leave two seconds and more intervals, and do soldering of each terminal. Be careful because the damage of the product is often started at the time of the hand solder.

4. Repairing

Repair should not be done after the LEDs have been soldered. When repairing is unavoidable, a double-head soldering iron should be used (as below figure). It should be confirmed beforehand whether the characteristics of the LEDs will or will not be damaged by repairing.

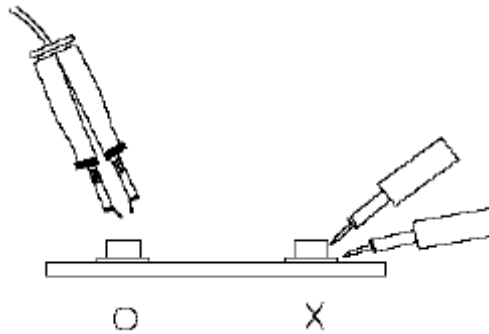

5. Caution in ESD

Static Electricity and surge damages the LED. It is recommended to use a wristband or anti-electrostatic glove when handling the LED. All devices, equipment and machinery must be properly grounded.

Revision History

Changes since last revision	Page	Version No.	Revision Date
Initial Release		1.0	05-31-2018
Format Adjustment		1.1	07-01-2018
Revise the drawing; update the precaution.	7, 10	1.2	07-31-2019

DISCLAIMER

INOLUX reserves the right to make changes without further notice to any products herein to improve reliability, function or design. INOLUX does not assume any liability arising out of the application or use of any product or circuit described herein; neither does it convey any license under its patent rights, nor the rights of others.

LIFE SUPPORT POLICY

INOLUX's products are not authorized for use as critical components in life support devices or systems without the express written approval of the President of INOLUX or INOLUX CORPORATION. As used herein:

1. Life support devices or systems are devices or systems which, (a) are intended for surgical implant into the body, or (b) support or sustain life, and (c) whose failure to perform when properly used in accordance with instructions for use provided in the labeling, can be reasonably expected to result in a significant injury of the user.
2. A critical component in any component of a life support device or system whose failure to perform can be reasonably expected to cause the failure of the life support device or system, or to affect its safety or effectiveness.