

Features

- Low power consumption
- High Efficiency
- 5 mm Lamp
- Easy to assembly
- Color Diffused lens
- Good control and free combinations on the colors of Lamps
- Compliance with EU REACH
- The product itself remain within RoHS compliant version

Applications

- Communication
- Industry
- Computer

Description

- CBI (Circuit Board Indicator) is a black plastic right angel holder (Housing).
- CBI (Circuit Board Indicator) is available in a wide variety of packages, including top-view (Spacer) or right angle and horizontal or vertical arrays which is stackable and easy to assembly.

Package Dimensions in mm

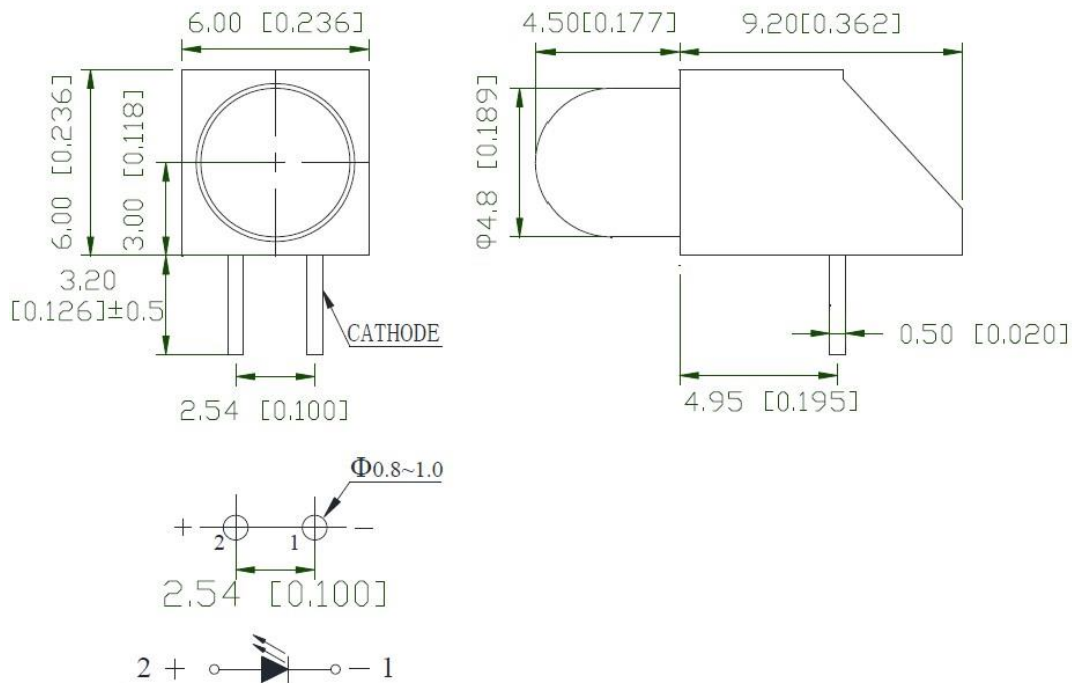

Figure 1. INH-5SXX60 series Package Dimensions

Notes

1. All dimensions are in millimeters (inches).
2. Tolerance is ± 0.25 mm (.010") unless otherwise noted.
3. Protruded resin under flange is 1.0mm (.039") max.

Absolute Maximum Rating at 25°C

Product	Emission Color	P _d (mW)	I _F (mA)	I _{FP} * (mA)	V _R (V)	T _{OP} (°C)	T _{ST} (°C)
INH-5SAUA60	Amber	65	25	100	5	-40°C~+80°C	-40°C~+85°C
INH-5SGUYG60	Yellow Green	65	25	100	5	-40°C~+80°C	-40°C~+85°C
INH-5SRUDR60	Deep Red	65	25	100	5	-40°C~+80°C	-40°C~+85°C
INH-5SYUY60	Yellow	65	25	100	5	-40°C~+80°C	-40°C~+85°C

Notes

1. Derate linearly as shown in derating curve.
2. Duty Factor = 10%, Frequency = 1kHz.

Electrical and Optical Characteristic (@ 25°C)

Product	Emission Color	I _F (mA)	V _F (V)		λ(nm)			Viewing Angle	I _V (mcd)	
			min	max	λ _D	λ _P	Δλ	2θ1/2	min	typ.
INH-5SAUA60	Amber	20	1.6	2.6	603	606	35	60	13	20
INH-5SGUYG60	Yellow Green	20	1.6	2.6	571	565	20	60	13	30
INH-5SRUDR60	Deep Red	20	1.6	2.4	640	660	45	60	90	160
INH-5SYUY60	Yellow	20	1.6	2.6	588	590	35	60	13	20

Notes

- Brightness tolerance = +/- 10%
- Luminous intensity is measured with a light sensor and filter combination that approximates the CIE eye-response curve.
- 2 θ 1/2 is the o-axis angle where the luminous intensity is 1/2 the peak intensity.
- The dominant wavelength (λ_D) is derived from the CIE chromaticity diagram and represents the single wavelength which defines the color of the device.

ESD Precaution

ATTENTION: Electrostatic Discharge (ESD) protection



The symbol above denotes that ESD precaution is needed. ESD protection for GaP and AlGaAs based chips is necessary even though they are relatively safe in the presence of low static-electric discharge. Parts built with AlInGaP, GaN, or/and InGaN based chips are STATIC SENSITIVE devices. ESD precaution must be taken during design and assembly.

If manual work or processing is needed, please ensure the device is adequately protected from ESD during the process.

Please be advised that normal static precautions should be taken in the handling and assembly of this device to prevent damage or degradation which may be induced by electrostatic discharge (ESD).

Typical Characteristic Curves: A, YG, DR, Y

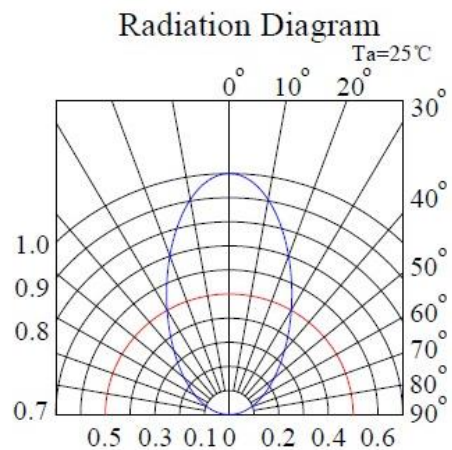
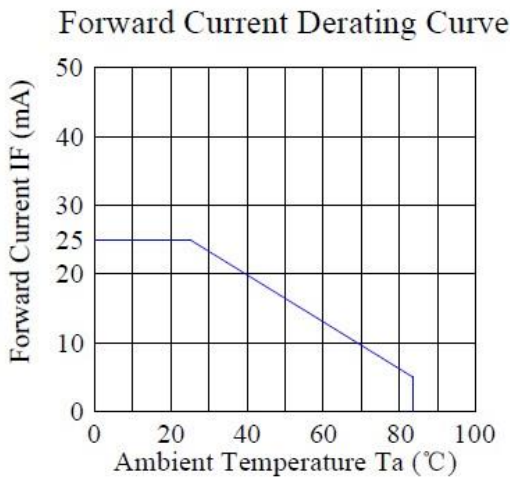
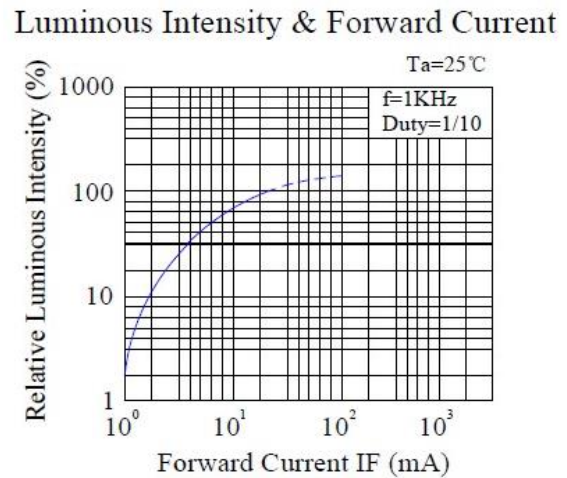
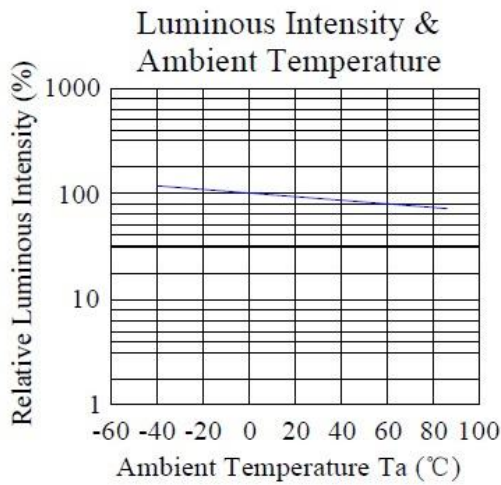
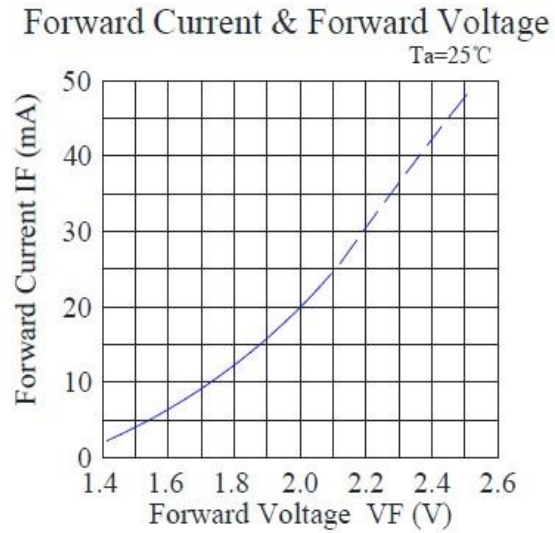
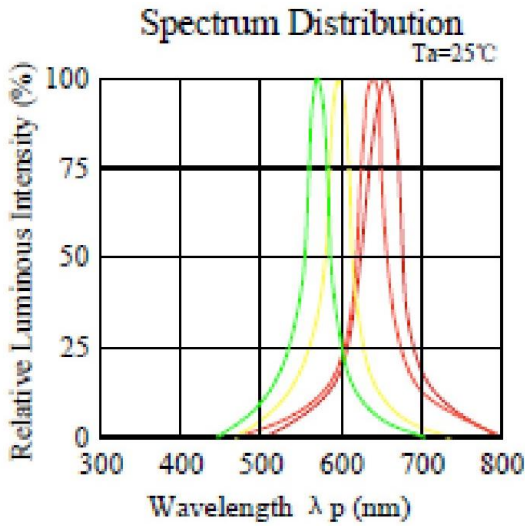

Ordering Information

Product	Emission Color	Test Current IF (mA)	Luminous Intensity IV (mcd) (Typ.)	Forward Voltage VF (V) (Typ.)	Orderable Part Number
INH-5SAUA60	Amber	20	20	2.0	INH-5SAUA60
INH-5SGUYG60	Yellow Green	20	30	2.0	INH-5SGUYG60
INH-5SRUDR60	Deep Red	20	160	2.0	INH-5SRUDR60
INH-5SYUY60	Yellow	20	20	2.0	INH-5SYUY60

Label Specifications

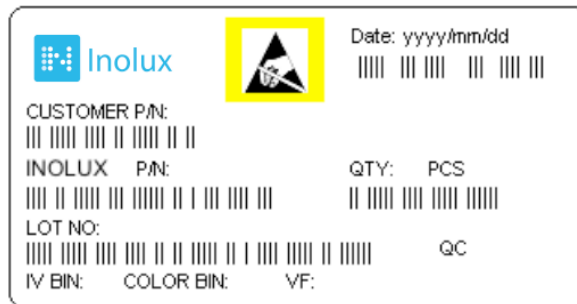



INH-5SXX60 Series
5mm Round, Single Lamp
Single Level Circuit Board Indicator

Inolux P/N:

I	N	H	-	5	S	X	X	6	0	-	X	X	X	X
Inolux Through Hole with Housing				Package	Lamp	Lens	Color	View Angle		Customized Stamp-off				
				5 = 5mm Round	S = 1 Lamp	AU = Amber Diffused GU = Green Diffused RU = Red Diffused YU = Yellow Diffused	A = 605nm YG = 570nm DR = 624nm Y = 590nm	60 = 60 deg.						

Lot No.:

Z	2	0	1	7	01	24	001
Internal Tracker	Year (2017, 2018,)				Month	Date	Serial



Revision History

Changes since last revision	Page	Version No.	Revision Date
Initial Release		1.0	06-19-2020

DISCLAIMER

INOLUX reserves the right to make changes without further notice to any products herein to improve reliability, function or design. INOLUX does not assume any liability arising out of the application or use of any product or circuit described herein; neither does it convey any license under its patent rights, nor the rights of others.

LIFE SUPPORT POLICY

INOLUX's products are not authorized for use as critical components in life support devices or systems without the express written approval of the President of INOLUX or INOLUX CORPORATION. As used herein:

1. Life support devices or systems are devices or systems which, (a) are intended for surgical implant into the body, or (b) support or sustain life, and (c) whose failure to perform when properly used in accordance with instructions for use provided in the labeling, can be reasonably expected to result in a significant injury of the user.
2. A critical component in any component of a life support device or system whose failure to perform can be reasonably expected to cause the failure of the life support device or system, or to affect its safety or effectiveness.