

Features

- 0.56" (14.20mm) Matrix Height
- Single Digit Display
- Black/Grey Face , White Segment
- IC compatible, Easy assembly
- Dynamic drive connect
- RoHS Compliant, Pb Free

Applications

- Consumer Electronics
- Industrial Equipment

Description

The INND-SS56 series is a 0.56" single digit display. It is a SMD type LED display which can be used in various applications.

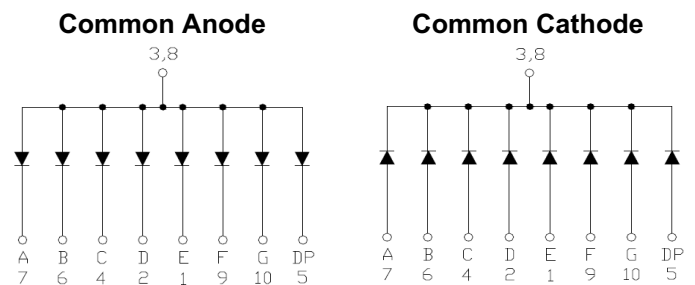


Figure 1. INND-SS56 series Internal Circuit Diagram

Package Dimensions

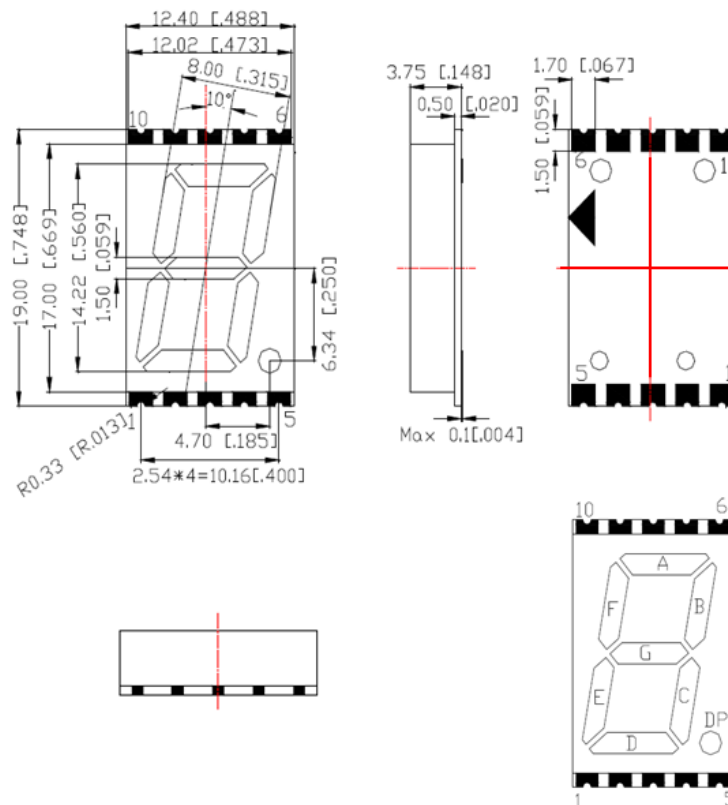


Figure 2. INND-SS56 series Package Dimensions

Absolute Maximum Rating at 25°C (Note 1)

Product (Per Segment)	Emission Color	Technology	P _d (mW)	I _F (mA)	I _{FP} * (mA)	V _R (V)	Derate From 25°C (mA/°C)	T _{OP} (°C)	T _{ST} (°C)
INND-SS56YGXX	Yellow Green	AlGaInP	70	25	90	5	0.33	-40°C~+105°C	-40°C~+105°C
INND-SS56YXX	Yellow	AlGaInP	70	25	90	5	0.33	-40°C~+105°C	-40°C~+105°C
INND-SS56AXX	Amber	AlGaInP	70	25	90	5	0.33	-40°C~+105°C	-40°C~+105°C
INND-SS56RXX	Red	AlGaInP	70	25	90	5	0.33	-40°C~+105°C	-40°C~+105°C
INND-SS56DRXX	Deep Red	AlGaInP	70	25	90	5	0.33	-40°C~+105°C	-40°C~+105°C
INND-SS56GXX	Green	InGaN	114	30	100	5	0.4	-40°C~+105°C	-40°C~+105°C
INND-SS56BXX	Blue	InGaN	114	30	100	5	0.4	-40°C~+105°C	-40°C~+105°C
INND-SS56WXX	White	InGaN	114	30	100	5	0.4	-40°C~+105°C	-40°C~+105°C

Notes

1. Condition for IFP is pulse of 1/10 duty and 0.1msec width

Electrical Characteristics $T_A = 25^\circ\text{C}$ (Note 1)

Product (Per Segment)	Emission Color	VF(V)@20mA			λ (nm)@20mA		I*V(mcd)@10mA			IR(μ A)@VR=5V	IV-M @IF =10mA
		min	typ.	max	λ D	λ P	min	typ.	max	max	max
INND-SS56YGXX	Yellow Green	-	2.0	2.8	570	572	-	3	-	100	2:1
INND-SS56YXX	Yellow	-	2.0	2.8	590	592	-	17	-	100	2:1
INND-SS56AXX	Amber	-	2.0	2.8	605	612	-	18	-	100	2:1
INND-SS56RXX	Red	-	2.0	2.8	630	644	-	9	-	100	2:1
INND-SS56DRXX	Deep Red	-	2.0	2.8	645	660	-	8	-	100	2:1
INND-SS56GXX	Green	-	3.2	3.8	525	-	-	70	-	100	2:1
INND-SS56BXX	Blue	-	3.2	3.8	465	-	-	12	-	50	2:1
INND-SS56WXX	White	-	3.2	3.8	X: 0.27 Y: 0.25	-	-	60	-	50	2:1

Notes

1. Performance guaranteed only under conditions listed in above tables.

ESD Precaution

ATTENTION: Electrostatic Discharge (ESD) protection



The symbol above denotes that ESD precaution is needed. ESD protection for GaP and AlGaAs based chips is necessary even though they are relatively safe in the presence of low static-electric discharge. Parts built with AlInGaP, GaN, or/and InGaN based chips are STATIC SENSITIVE devices. ESD precaution must be taken during design and assembly. If manual work or processing is needed, please ensure the device is adequately protected from ESD during the process.

Please be advised that normal static precautions should be taken in the handling and assembly of this device to prevent damage or degradation which may be induced by electrostatic discharge (ESD).

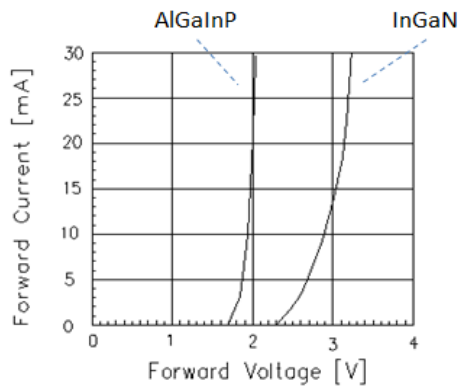
Characteristic Curves for YG, Y, A, R, DR, G


Fig 1. Forward Current vs. Forward Voltage

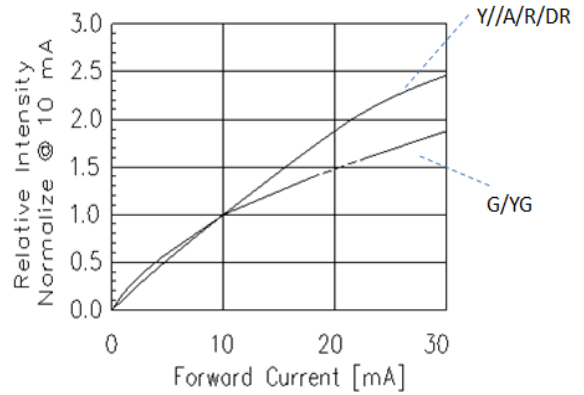


Fig 2. Relative Intensity vs. Forward Current

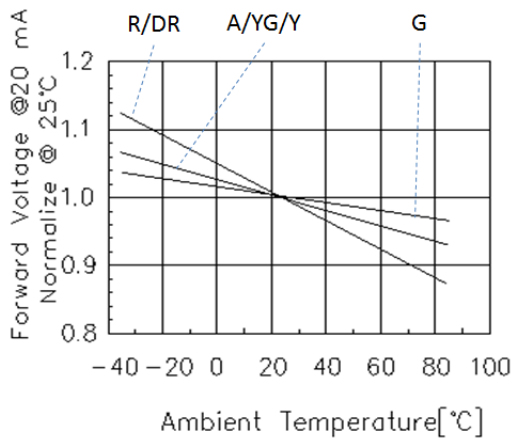


Fig 3. Forward Voltage vs. Temperature

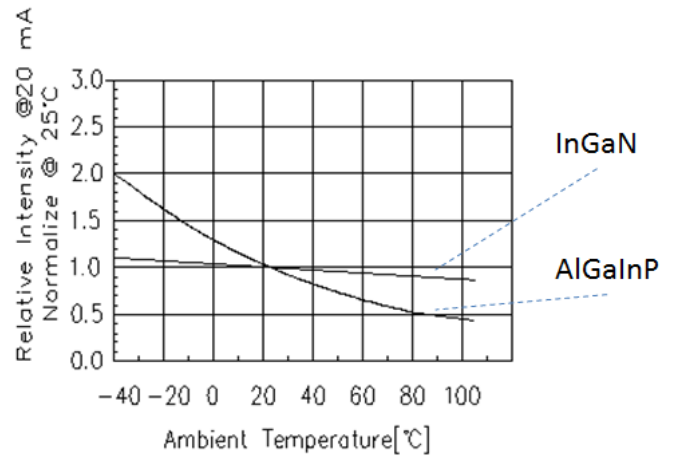


Fig 4. Relative Intensity vs. Temperature

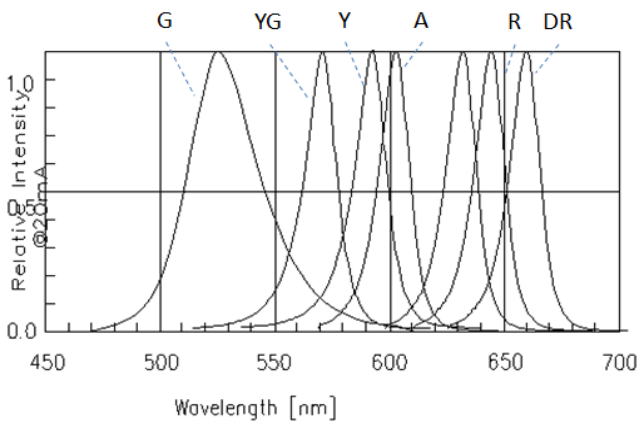


Fig 5. Relative Intensity vs. Wavelength

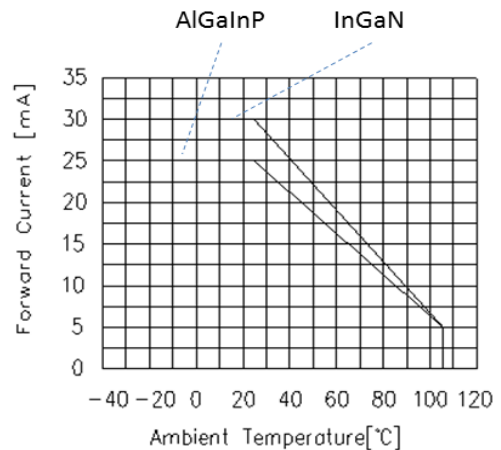


Fig 6. Forward current vs. Temperature

Characteristic Curves for B

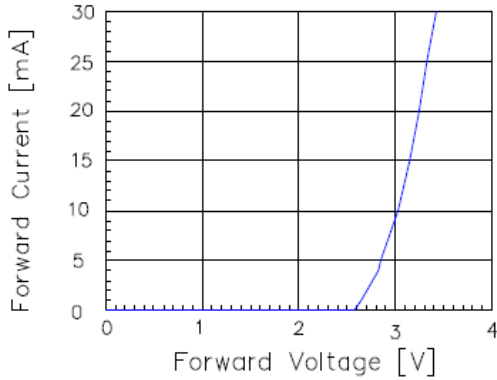


Fig 1. Forward Current vs. Forward Voltage

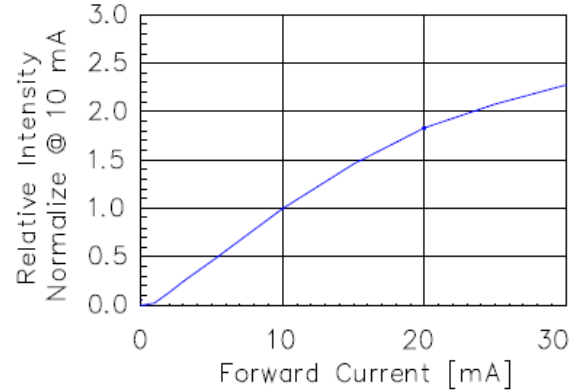


Fig 2. Relative Intensity vs. Forward Current

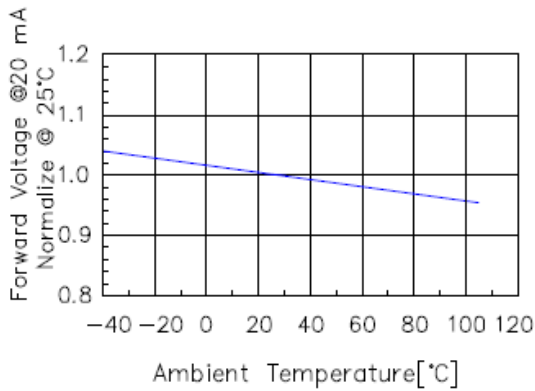


Fig 3. Forward Voltage vs. Temperature

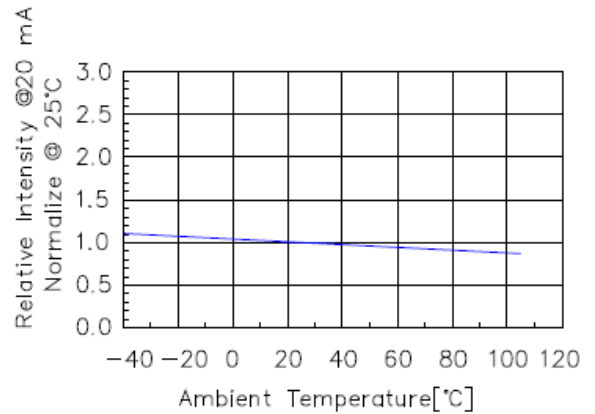


Fig 4. Relative Intensity vs. Temperature

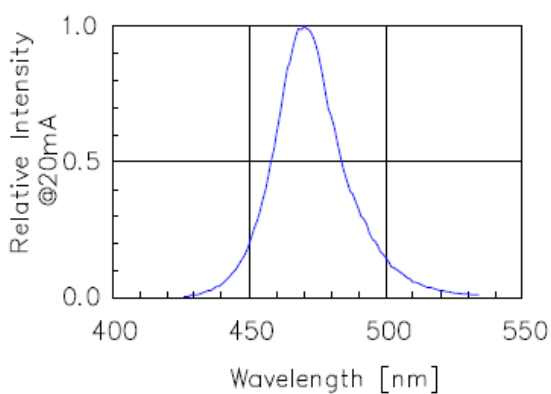


Fig 5. Relative Intensity vs. Wavelength

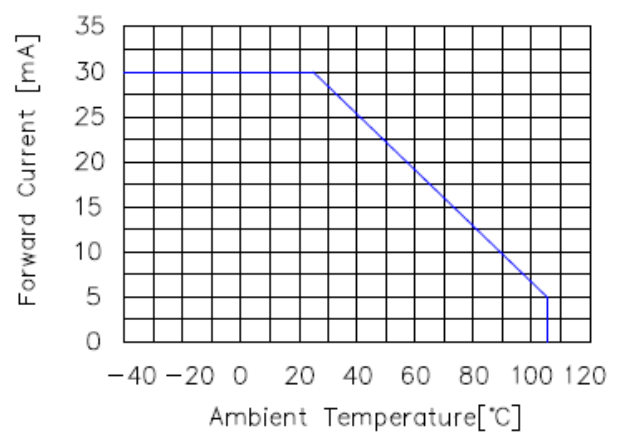


Fig 6. Forward current vs. Temperature

Characteristic Curves for W

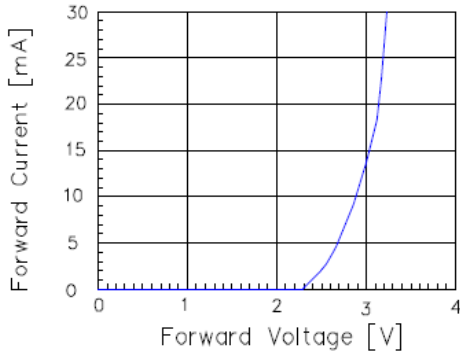


Fig 1. Forward Current vs. Forward Voltage

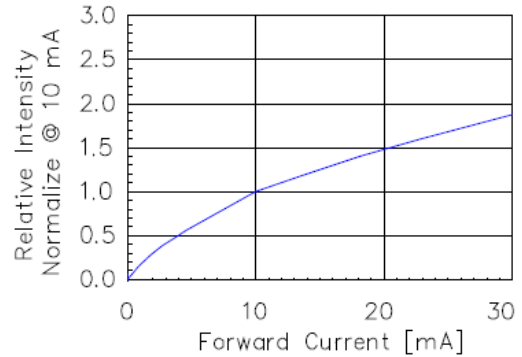


Fig 2. Relative Intensity vs. Forward Current

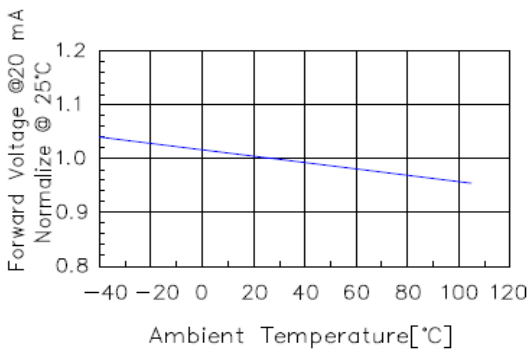


Fig 3. Forward Voltage vs. Temperature

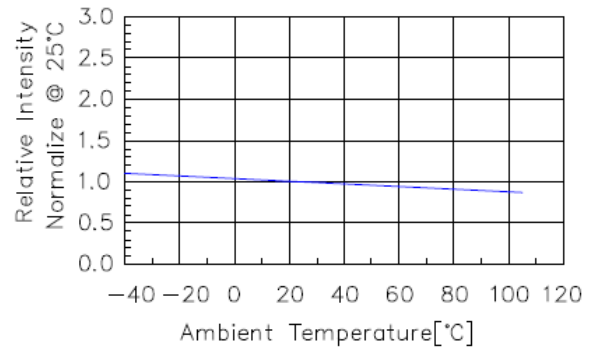


Fig 4. Relative Intensity vs. Temperature

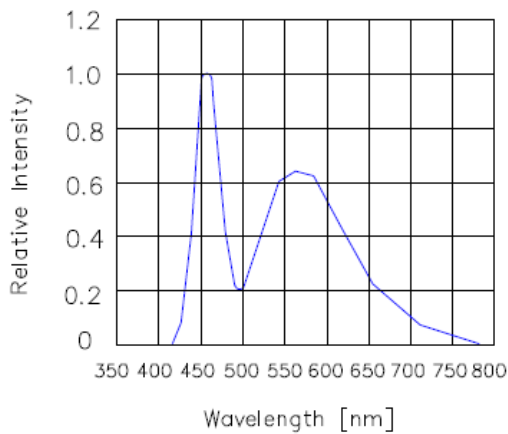


Fig 5. Relative Intensity vs. Wavelength

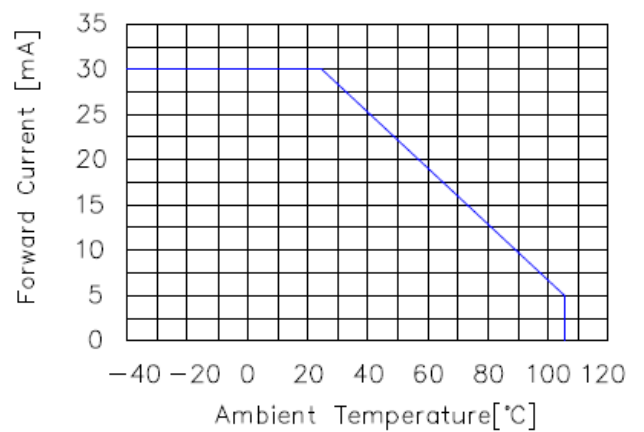
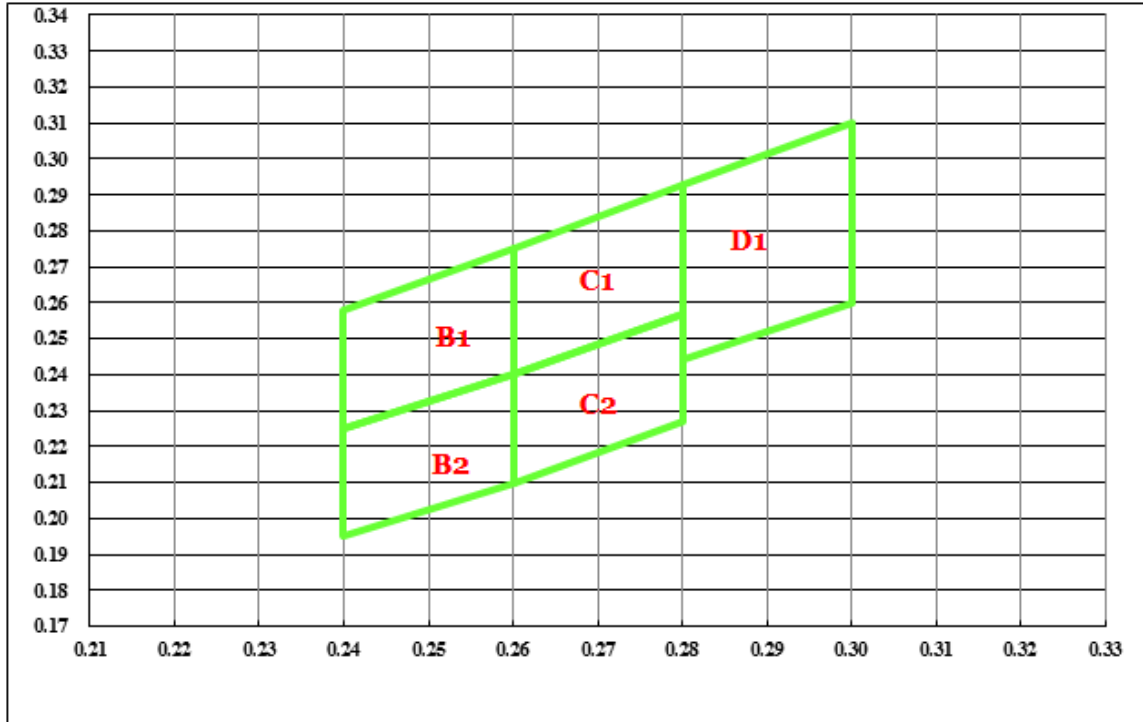


Fig 6. Forward current vs. Temperature

Chromaticity Bin (for White only)


B1				
X	0.240	0.240	0.260	0.260
Y	0.225	0.258	0.275	0.240

B2				
X	0.240	0.240	0.260	0.260
Y	0.195	0.225	0.240	0.210

C1				
X	0.260	0.260	0.280	0.280
Y	0.240	0.275	0.293	0.257

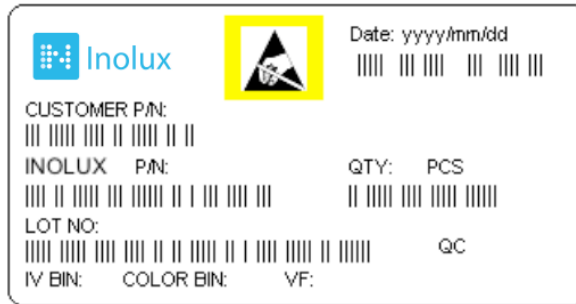
C2				
X	0.260	0.260	0.280	0.280
Y	0.210	0.240	0.257	0.227

D1				
X	0.280	0.280	0.300	0.300
Y	0.244	0.293	0.310	0.260

Ordering Information

Product	Emission Color	Technology	I*V(mcd) @10mA	VF(V) @20mA	Polarity	Face Color	Orderable Part Number
INND-SS56YGXX	Yellow Green	AlGaInP	3	2.0	Common Anode	Black	INND-SS56YGAB
					Common Cathode	Black	INND-SS56YGCB
					Common Anode	Grey	INND-SS56YGAG
					Common Cathode	Grey	INND-SS56YGCG
INND-SS56YXX	Yellow	AlGaInP	17	2.0	Common Anode	Black	INND-SS56YAB
					Common Cathode	Black	INND-SS56YCB
					Common Anode	Grey	INND-SS56YAG
					Common Cathode	Grey	INND-SS56YCG
INND-SS56AXX	Amber	AlGaInP	18	2.0	Common Anode	Black	INND-SS56AAB
					Common Cathode	Black	INND-SS56ACB
					Common Anode	Grey	INND-SS56AAG
					Common Cathode	Grey	INND-SS56ACG
INND-SS56RXX	Red	AlGaInP	9	2.0	Common Anode	Black	INND-SS56RAB
					Common Cathode	Black	INND-SS56RCB
					Common Anode	Grey	INND-SS56RAG
					Common Cathode	Grey	INND-SS56RCG

Product	Emission Color	Technology	I*V(mcd) @10mA	VF(V) @20mA	Polarity	Face Color	Orderable Part Number
INND-SS56DRXX	Deep Red	AlGaInP	8	2.0	Common Anode	Black	INND-SS56DRAB
					Common Cathode	Black	INND-SS56DRCB
					Common Anode	Grey	INND-SS56DRAG
					Common Cathode	Grey	INND-SS56DRCG
INND-SS56GXX	Green	InGaN	70	3.2	Common Anode	Black	INND-SS56GAB
					Common Cathode	Black	INND-SS56GCB
					Common Anode	Grey	INND-SS56GAG
					Common Cathode	Grey	INND-SS56GCG
INND-SS56BXX	Blue	InGaN	12	3.2	Common Anode	Black	INND-SS56BAB
					Common Cathode	Black	INND-SS56BCB
					Common Anode	Grey	INND-SS56BAG
					Common Cathode	Grey	INND-SS56BCG
INND-SS56WXX	White	InGaN	60	3.2	Common Anode	Black	INND-SS56WAB
					Common Cathode	Black	INND-SS56WCB
					Common Anode	Grey	INND-SS56WAG
					Common Cathode	Grey	INND-SS56WCG

Label Specifications

Inolux P/N:

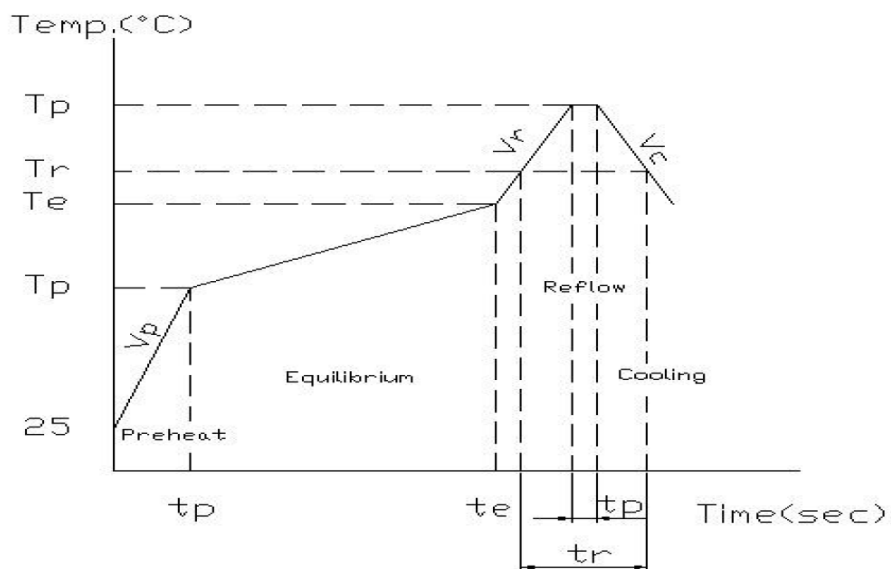
I	N	N	D	-	S	S	5	6	X	X	X	-	X	X	X	X
Inolux		Display Type	Display Type	Dimension	Color	Polarity	Face Color	Customized Stamp-off								
		ND = Numeric Display	S: SMD Type S: Single	56 = 0.56" Display Height	YG: 570 nm Y: 590 nm A: 605 nm R: 630 nm DR: 660 nm G: 525 nm B: 465 nm W: X: 0.27 Y: 0.25	A = Common Anode C=Common Cathode	B = Black G = Grey									

Lot No.:

Z	2	0	1	7	01	24	001
Internal Tracker	Year (2017, 2018,)				Month	Date	Serial

Reflow Soldering

Area	Title	Symbol	Min	Max	Unit
(1)Preheat	Ramp-up rate	Vp	1	5	°C/sec
	temperature	Tp	150	—	°C
	time	tp	—	—	sec
(2)Equilibrium	Ramp-up rate	Ve	—	—	°C/sec
	temperature	Te	150	200	°C
	Time	te	60	120	sec
(3)Reflow	Ramp-up rate	Vr	1	5	°C/sec
	temperature	Tr	220	—	°C
	Time	tr	—	60	sec
	Peak temperature	Trp	—	260	°C
	Peak time	trp	—	10	sec
(4)Cooling	Ramp-down rate	Vc	3	6	°C/sec



Soldering Iron

Basic Spec is ≤ 4 sec. when 260°C (+10°C → -1 second). Power dissipation of Iron should be less than 15W. Surface temperature should be under 230°C

Rework

Rework should be completed within 4 second under 245°C

Revision History

Changes since last revision	Page	Version No.	Revision Date
Initial Release		1.0	07-12-2017
Revise Information	11	1.1	10-16-2021

DISCLAIMER

INOLUX reserves the right to make changes without further notice to any products herein to improve reliability, function or design. INOLUX does not assume any liability arising out of the application or use of any product or circuit described herein; neither does it convey any license under its patent rights, nor the rights of others.

LIFE SUPPORT POLICY

INOLUX's products are not authorized for use as critical components in life support devices or systems without the express written approval of the President of INOLUX or INOLUX CORPORATION. As used herein:

1. Life support devices or systems are devices or systems which, (a) are intended for surgical implant into the body, or (b) support or sustain life, and (c) whose failure to perform when properly used in accordance with instructions for use provided in the labeling, can be reasonably expected to result in a significant injury of the user.
2. A critical component in any component of a life support device or system whose failure to perform can be reasonably expected to cause the failure of the life support device or system, or to affect its safety or effectiveness.